

# SMART LIFT SPIDER 225C

REACH  
 ↑ VERT. 2500 mm  
 → HORZ. 3500 mm  
 MAX. up to 225 kg

The 3arm Smart Lift Spider 225C is an electronic rope balancer mounted on a column with two radial arms for manually handling loads up to 225kg

The 3arm Spider features make this rope balancer unique.

● MEASURING CELL

The application of a measuring cell leads to an optimum running performance. Self-balancing and the weight of the load is displayed exactly

● ENDLESS ROTATION

Rotary units are installed on the operating handle and the column. This allows endless turning movement of the load and radial arms.

● EASY PROGRAMMING

The device allows to easily set up different speeds as well as reducing the speed at the pick-up and release points.

● MIDDLE HINGE

The middle hinge connects the two radial arms allowing to reach every point within the operating radius.

● CUSTOMIZABLE

Flexible software to customize the device with different end effectors or other input output application needs

# SPIDER 225C

TECHNICAL DATA

<b>Load Capacity</b>	0-225 kg
<b>Power Supply</b>	230 V
<b>Lifting speed</b>	Up to 392 mm/s. Adjustable in different heights. Pick up/release point.
<b>Radial arms</b>	Length: 2.5m, 3m and 3.5m.
<b>Cable Stroke</b>	2.5m
<b>Controls</b>	Handle mode and load mode

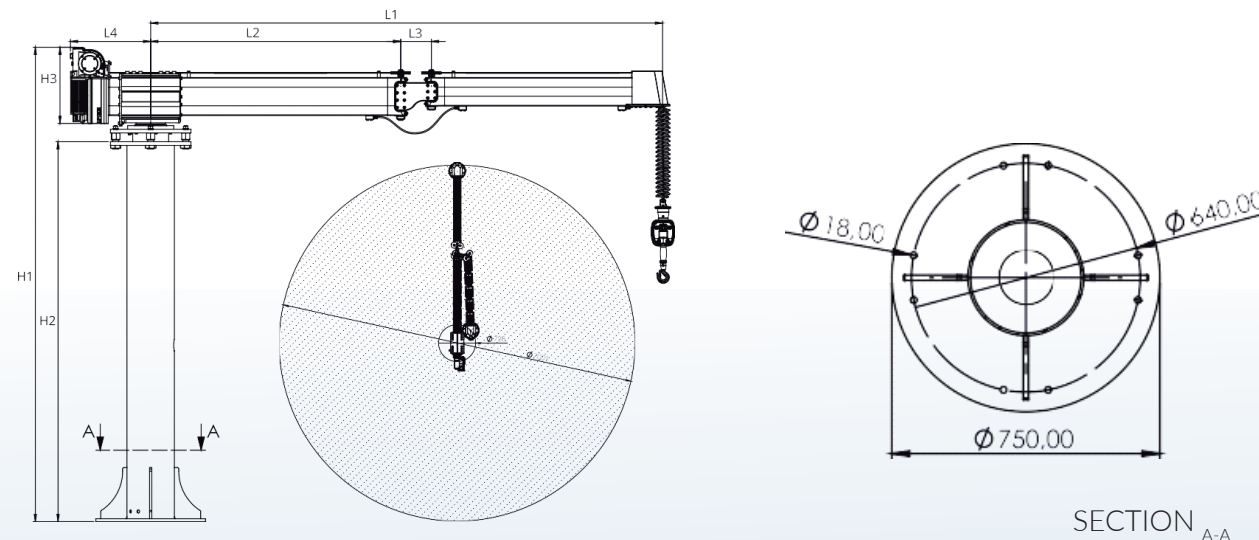

Measures	L1	L2	L3	L4	H1	H2	H3
mm	3500	1710	210	549	3240	2595	520

