

SMART LIFT SPIDER 150C

REACH
 ↑ VERT. 2500 mm
 → HORZ. 4000 mm
 MAX. up to 150 kg

The 3arm Smart Lift Spider 150C is an electronic rope balancer mounted on a column with two radial arms for manually handling loads up to 150kg

The 3arm Spider features make this rope balancer unique.

- **MEASURING CELL**

The application of a measuring cell leads to an optimum running performance. Self-balancing and the weight of the load is displayed exactly

- **ENDLESS ROTATION**

Rotary units are installed on the operating handle and the column. This allows endless turning movement of the load and radial arms.

- **EASY PROGRAMMING**

The device allows to easily set up different speeds as well as reducing the speed at the pick-up and release points.

- **MIDDLE HINGE**

The middle hinge connects the two radial arms allowing to reach every point within the operating radius.

- **CUSTOMIZABLE**

Flexible software to customize the device with different end effectors or other input output application needs

SPIDER 150C

TECHNICAL DATA

Load Capacity	0-150 Kg
Power Supply	230V
Lifting speed	Up to 420mm/s. Adjustable in different heights. Pick up/release point
Radial arms	Length: 2.5m, 3m, 3.5m and 4m
Cable Stroke	2.5m
Controls	Handle mode and load mode

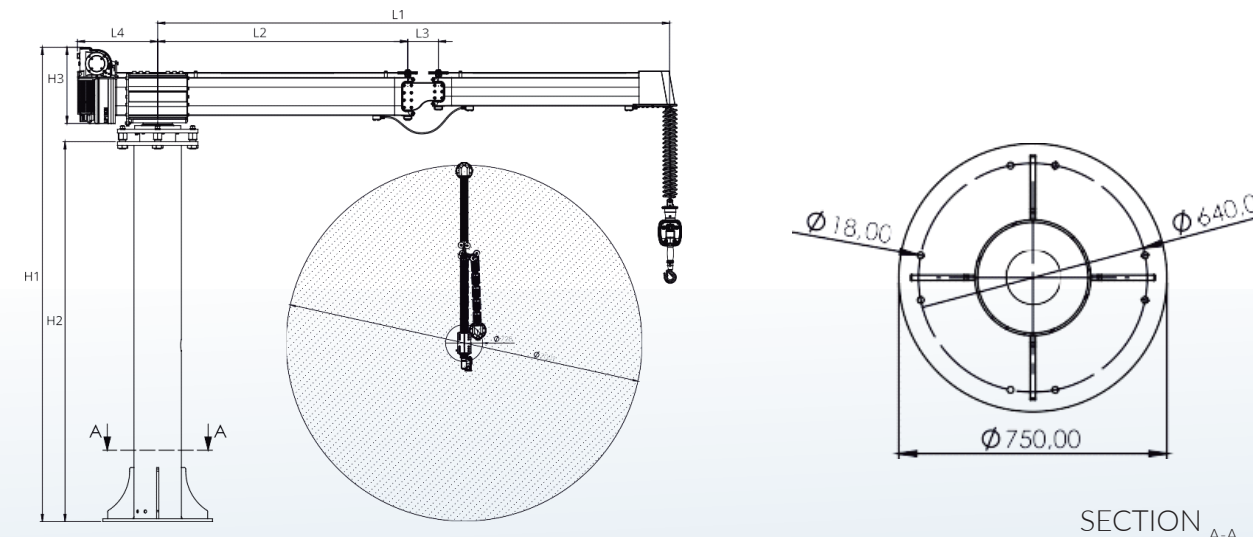

Measures	L1	L2	L3	L4	H1	H2	H3
mm	4000	1960	210	513	3162	2595	497

