

LIFTING AND TRANSPORT EQUIPMENT

2024 2025

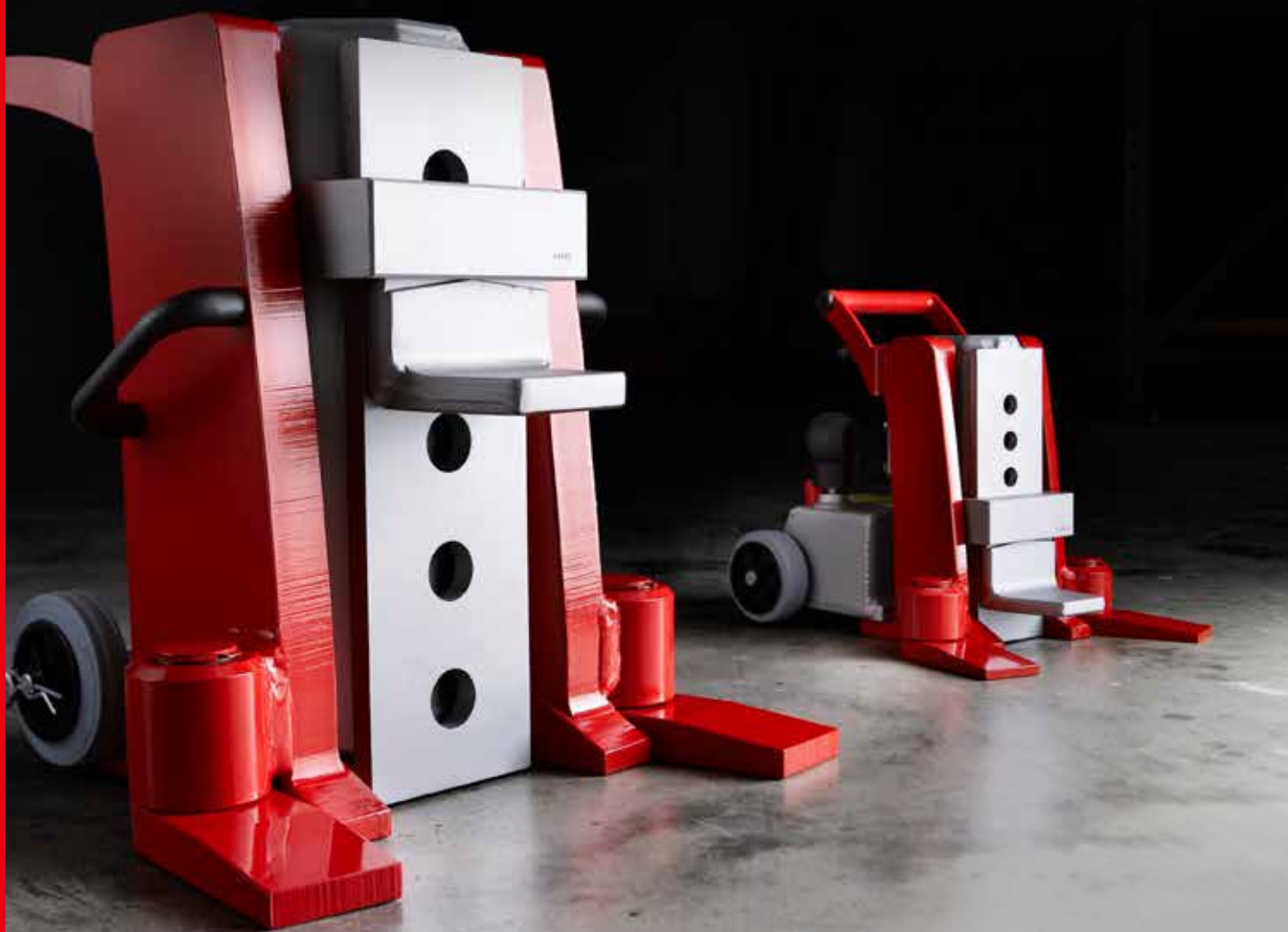

JUNG
●●●
JUNG-HEBETECHNIK.DE

JUST MOV

VE SAFELY.

Our aim is to make lifting and moving heavy loads easier, safer and more ergonomic for the user.

JUNG

**WE MAKE
A DIFFERENCE.
TONS OF IT.**



QUALITY

You can always trust in the quality and durability of our products. To manufacture highest quality we use most modern machines and assure a continuously high standard by a certified quality management system.

State of the art CNC technology, advanced welding robots and a certified quality management system (DIN EN ISO 9001) assure a consistently high level of product quality. Each hydraulic jack is subjected to a pre-shipment function test and receives a test badge displaying the next recommended maintenance check date. Each self-powered trolley is also subjected to a pre-shipment function test.

Following products are ANSI/ASME (USA) tested: JH G-plus, JH G-plus EX, JHS, JKB, series K, series M.

PROCESSES & ENVIRONMENT

As an ISO 9001 certified company we continuously improve our processes by involving our customers, employees and suppliers.





JUNG on the move.

SOME STATIONS.

1972

FOUNDING

Karl-Heinz Jung founds the company JUNG in Kernen near Stuttgart.



1982

FIRST COMPANY BUILDING

The first own company building is built at the current location in Waiblingen.



1993

OWN SALES

JUNG separates from the former exclusive distribution partner and builds up its own sales department.



2001

NEW BUILDING

JUNG doubles the production area by building a new hall at the Waiblingen site.



2002

TUGGER TRAIN

JUNG expands its product range and now also produces trailers for in-house logistics.



2003

FOOT MASTER®

JUNG starts selling FOOT MASTER® leveling castors.





In several stages, JUNG was expanded from a one-man operation to an international company. In the meantime JUNG has more than 55 employees. Many of them have been with the company for a long time, in some cases even completed their training at JUNG. Our employees have the goal of working together to achieve the best for our customers. Our ambition for over 50 years is to make lifting and moving heavy loads easier, safer and more ergonomic for the user. According to our slogan: JUNG = Innovation, Karl-Heinz Jung and Thomas Würthele, together with the JUNG employees, have developed a large number of different devices to be able to offer the right product for every application.

2022

50 YEARS

The JUNG company celebrates its 50th anniversary.

2020



SUPPORT TECHNOLOGY

Expansion of the product range with support technology and surface protection

2017



GORR TRANSPORTECHNIK

JUNG acquires the company Gorr Transporttechnik GmbH in Eschwege.

2017



LIFTING BAGS

JUNG starts the distribution of lifting bags.

2008

INDUSTRIAL HYDRAULICS

JUNG is again expanding its product range to include industrial hydraulics.

2009

EXPANSION

JUNG further expands the production area by another hall at the Waiblingen site

2014



NEW PRODUCT LINE

JUNG presents the first electric-powered trolley JLA-e 15/30 G.

RESPONSIBILITY AWARENESS.

A dark industrial setting, possibly a factory or warehouse, with a white mobile robot in the foreground. The robot has a control panel with various buttons and a small display. In the background, there are large metal cabinets and stacks of materials. The lighting is dramatic, with strong highlights on the robot and the floor, and deep shadows elsewhere.

CUSTOMER

The satisfaction of our customers is in the center of our efforts. Due to our creativity and our expertise, we realize individual customer requests.

STAFF

The company's success is depending on our staff members. Therefore, we are continuously investing in training and development and support the experience and competence through long-term employment.



SOCIAL COMMITMENT

We are a part of Waiblingen and are glad to support regional social and charitable organizations.

ENVIRONMENT

We meet our ecological responsibilities in our daily work flow. We utilize our own solar power, obtain power from regenerative energy sources and have examined our ecological accountability under the Ecofit project.

YOUR ADVANTAGES FROM OUR SERVICES:

MADE IN GERMANY

We have over 50 years of experience in the development and manufacture of rigging equipment. Our lifting and transport equipment has proven itself thousands of times as essential tools in all areas in which the movement of heavy loads is required.



REPAIR & MAINTENANCE SERVICE

Even after many years of usage, our products are still ready for use. To achieve this we provide maintenance and repair service, as well as replacement parts.

AVAILABILITY

As a rule, we have extensive stock for a large number of our series products. In most cases, the products are therefore available within a short time.

WARRANTY

We provide a 5 year warranty on all jacks and transport trolleys when products are used as directed – except for JLA-e, where we provide a 1 year warranty or 1000 operating hours.



LIST OF CONTENT

Jacks for loads up to 30 metric tons – series JH-G plus	15
Jack sets for loads up to 20 metric tons – series JHS	18
Hydraulic pressure blocks JD	20
Electrical pumps JPE	22
Hand pump JP and air hydraulic pump JPL	23
Useful accessories for jacks and hydraulic hoses JS	24
Trolley information and overview	25
Transport trolleys for loads up to 24 metric tons – series K	28
Transport trolleys for loads up to 28 metric tons – series K professional	30
Revolving transport trolleys for loads up to 28 metric tons – series JKB	34
Multi-purpose trolley for loads up to 15 metric tons – series M	38
Transport trolleys for loads up to 48 metric tons – series S	40
Tandem transport trolleys for loads up to 14 metric tons – series K	42
Tandem transport trolleys for loads up to 60 metric tons – series G	43
Twistlock / „Weld-on Cone“ transport of containers up to 60 metric tons	44
Air-powered trolley – for loads up to 30 metric tons	50
Electric-powered trolleys – for loads up to 50 metric tons	52
Transport trolleys for loads up to 60 metric tons – series G	58
Transport trolleys for loads up to 200 metric tons – series H	60
Accessories for forklifts	62
Sturdy castors for any application	64
Useful accessories for transport trolleys	66
Hydro-transporter	69
Optional galvanized equipment and custom solutions	70

LIFT **SAFELY.**

Easy. Handy. Strong.



JUNG
L O O L



» THE LIGHT-WEIGHT JACK: JH-G



Professional solutions. For professionals.

SAVE WEIGHT

Extreme weight reduction by improved construction.

PATENTED

Work and lift safely with our patented lifting toe system (Pat.-No. 4413478).

SECURE AND TEAR RESISTANT

Swiveling safety toe made from die-forged steel for extreme robustness that prevents fractures. The advanced strength steel is impact resistant and provides optimal safety.

RELIABLE STURDY

Sturdy, 180° swivelling feet - for easy and safe positioning in every situation.

FLEXIBLE

Removable handle on JH 6 G plus and JH 10 G plus.

EXPANDABLE

Custom-made upon request, available with side handles and/or a standard handle.

LOW COST

Easy maintenance by single removable pump unit; safety pressure relief valve with dirt filter prevents overloading. Also available without integrated pump unit. See JH G plus series EX version.

MAXIMUM OUTPUT

Maximum output due to reduced friction in the lifting track with our patented slide shoe design.

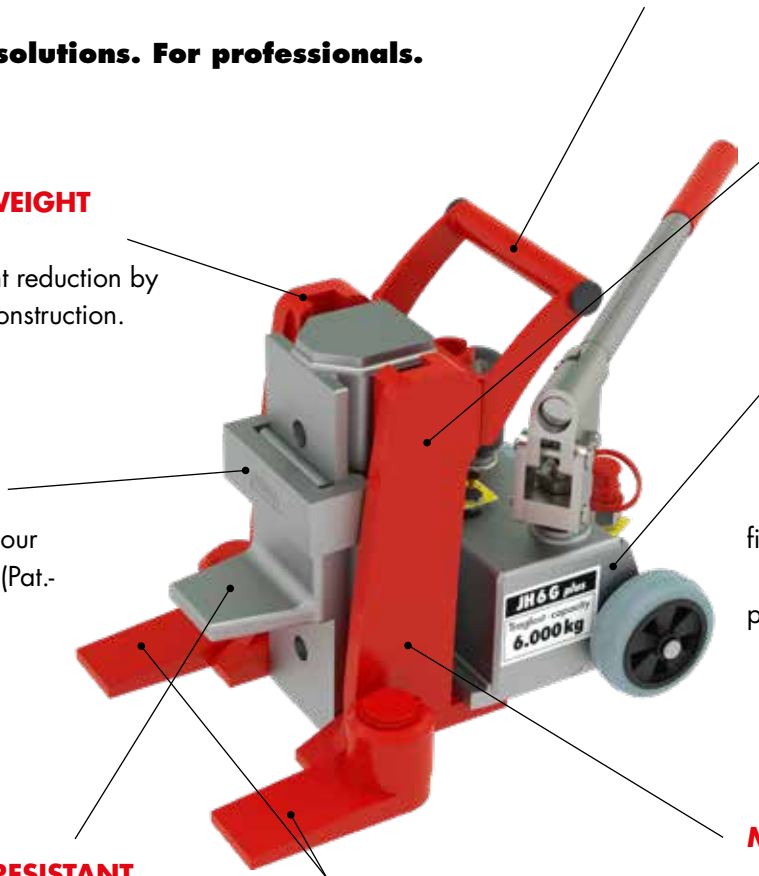

i Technical drawings of the respective devices can be found at jung-hebetechnik.de

» Swiveling lifting toe for safe and optimal adjustment to loads on varying inclines up to +6°.

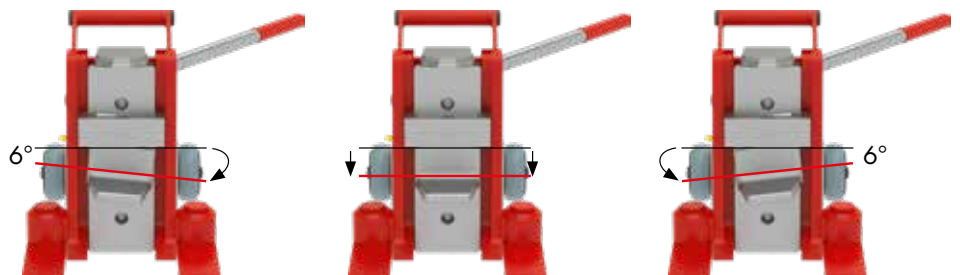

JACKS

SERIES JH-G PLUS EX



Without integrated pump unit, for loads up to 30 metric tons

i DESCRIPTION

■ Integrated spring return retracts piston automatically (see picture 1) on JH 15 up to JH 30 G plus Ex.

■ Slide shoe design inside the guiding track prevents twisting of the piston inside the lifting cylinder. This guarantees better force distribution, less friction and reduced wear compared to conventional jacks (see pict. 2).

■ Reduced maintenance costs due to removable stroke unit and easy to change slide shoes.

■ Extremely lightweight with high performance due to the use of high-quality material and innovative design.

■ Continuous adjustment to the load due to swiveling safety toe. Secure stability in every situation even in lifted position (see picture 3).

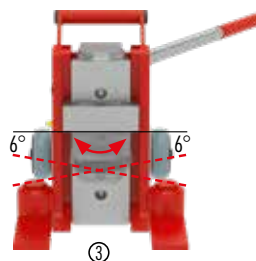
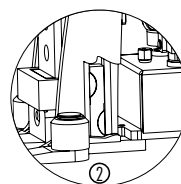
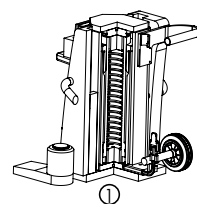

External pump necessary. Please refer to page 22 for electrical pumps, page 23 for hand pumps, for hydraulic hoses to page 24.



TYPE		JH 10 G PLUS EX	JH 15 G PLUS EX	JH 20 G PLUS EX	JH 30 G PLUS EX
Load capacity on top plate	kg	10 000	15 000	20 000	30 000
Stroke	mm	150	175	190	200
Minimum lift toe height	h 1 mm	15	20	20	20
Maximum lift toe height	h 2 mm	180	205	225	304
Lift toe adjustment	V mm	5 x 41	5 x 46	5 x 51	5 x 71
Top plate height	H 1 mm	275	310	340	420
Toe width front	L b mm	60	80	80	80
Toe depth	n L mm	55	64	64	64
Length feet in front	L 2 mm	270	340	360	380
Length feet on side	L 1 mm	251	230	330	370
Width	B mm	247	300	322	375
Height	H 2 mm	308	310	340	420
Cylinder volume	Liter	0,3	0,5	0,73	1,27
Weight	kg	29	42	55	95

Order No. ■ 11 610 106-G ■ 11 615 106-G ■ 11 620 106-G ■ 11 630 106-G

JACKS

SERIES JH-G PLUS

With integrated pump unit, for loads up to 20 metric tons

i DESCRIPTION

■ Slide shoe design inside the guiding track prevents twisting of the piston inside the lifting cylinder. This guarantees better force distribution, less friction and reduced wear compared to conventional jacks (see pict. 2).

■ JH 15/JH 20 G plus serial outfitted with fast stroke. Also available with spring return.

■ Reduced maintenance costs due to easy change slide shoes and removable pump unit.

■ Extremely lightweight with high performance due to the use of highquality material and innovative design.

■ Continuous adjustment to the load due to swiveling safety toe. Secure stability in every situation even in lifted position (see picture 3).

■ Die-forged steel toe provides impact resistance.

■ Safe operation due to ergonomic lowering screw.

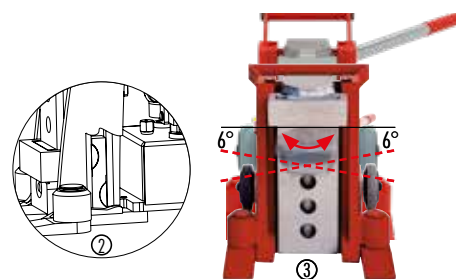

TYPE		JH 6 G PLUS	JH 10 G PLUS	JH 10 G PLUS KU
Load capacity on top plate	kg	6 000	10 000	10 000
Stroke	mm	140	150	108
Minimum lift toe height	h 1 mm	12	15	15
Maximum lift toe height	h 2 mm	157	180	138
Lift toe adjustment	V mm	6 x 29	5 x 41	4 x 41
Top plate height	H 1 mm	245	275	233
Toe width front	L b mm	50	60	60
Toe depth	n L mm	50	55	55
Length feet in front	L 2 mm	326	346	346
Length feet on side	L 1 mm	311	330	330
Width	B mm	233	247	247
Height	H 2 mm	280	310	233
Cylinder volume	Liter	0,18	0,3	0,21
Weight	kg	22	29	28

ORDER NO. ■ 01 060 102-G ■ 01 100 102-G ■ 01 100 103-G KU



JH 15 G plus in use combined with our JL 9 K

Custom orders available upon request:

JH 6 G plus with standard handle and side handles

Right: JH 10 G plus with side handles, without standard handle



TYPE		■ JH 15 G PLUS		■ JH 20 G PLUS	
Load capacity on top plate		kg	15 000		20 000
Stroke		mm	175		190
Minimum lift toe height	h 1	mm	20		20
Maximum lift toe height	h 2	mm	205		225
Lift toe adjustment	V	mm	5 x 46		5 x 51
Top plate height	H 1	mm	310		340
Toe width front	L b	mm	80		80
Toe depth	n L	mm	64		64
Length feet in front	L 2	mm	415		425
Length feet on side	L 1	mm	393		405
Width	B	mm	322		322
Height	H 2	mm	310		340
Cylinder volume		Liter	0,5		0,73
Weight		kg	48		60
ORDER NO.			■ 01 150 102-G		■ 01 200 102-G

HYDRAULIC JACK SETS

SERIES JHS

For loads up to 20 metric tons

i DESCRIPTION

■ 180° revolving housing, this allows the jack to be placed with long or with short feet to the load, if there is no space available under it.

■ More safety distance to the load because of the use of a separate pump and hoses.

■ Extra-large lift height: JHS 5 with lift toe 240 mm, with top plate maximum 580 mm. JHS 10 with lift toe 260 mm, with top plate maximum 610 mm.

■ Can also be used horizontally for pressing.

■ Large load capacity – up to 20 metric tons in set - with low net weight, therefore perfect for use on site or on the way due to easy change of location.



JSET 10/2



JSET 20/3

HYDRAULIC JACKS WITH PUMP AND HOSES IN ONE SET

TYPE	JSET 5/2	JSET 10/2	JSET 10/3	JSET 20/3
Jack	1 x JHS 5	2 x JHS 5	1 x JHS 10	2 x JHS 10
Hose	1 x JS 2	2 x JS 2	1 x JS 3	2 x JS 3
Pump	JP 26	JP 26	JP 26	JP 26
ORDER NO.	■ 20 405 200-S	■ 20 410 200-S	■ 20 410 301-S	■ 20 420 301-S

SINGLE HYDRAULIC JACKS JHS WITHOUT PUMP AND HOSE

TYPE	JHS 5	JHS 10	
Load capacity on top plate	kg	5 000	10 000
Minimum lift toe height	h 1 mm	15	20
Maximum lift toe height	h 2 mm	240	260
Top plate height	H 1 mm	350	370
Maximum top plate height	H 2 mm	580	610
Toe width front	L b mm	45	60
Useable toe depth	n L mm	40	55
Diameter top plate	d mm	60	80
Length toe supported	L 2 mm	170	205
Length toe exposed	L 1 mm	220	260
Width	B mm	145	200
Cylinder volume	L	0,3	0,47
Weight	kg	11	20
ORDER NO.	■ 01 020 050-0	■ 01 020 101-0	



■ JHS 10 ku as set (JSET 20/3 ku) suits perfectly to the container transport trolleys (see page 44 & 45).

■ High capacity at low weight.

■ Swiveling elbowed nipple allows hose connection from various directions.

■ Swiveling lifting toe assures optimal adjustment to the load, along with safe and stable support even in raised position (see picture page 14).

■ Pump unit separated from jack, flexible use, ideal also for confined spaces, also operates in horizontal position.

■ JHS 10 ku now with practical swivel protection. This avoids damage to the hose (see picture 1).



External pump necessary. Please refer to page 22 for electrical pumps, page 23 for hand pumps, for hydraulic hoses to page 24.



JSET 20/3 KU

HYDRAULIC JACKS WITH PUMP AND HOSES IN ONE SET

TYPE	JSET 10/3 KU	JSET 20/3 KU
Jack	1 x JHS 10 ku	2 x JHS 10 ku
Hose	1 x JS 3	2 x JS 3
Pump	JP 26	JP 26
ORDER NO.	20 410 305-S	20 420 305-S

SINGLE HYDRAULIC JACK JHS 10 KU WITHOUT PUMP AND HOSE

TYPE	JHS 10 KU		
Load capacity on top plate	kg		10 000
Minimum lift toe height	h 1	mm	20
Maximum lift toe height	h 2	mm	288
Lift toe adjustment	V	mm	5 x 41
Top plate height	H 1	mm	265
Maximum top plate height	H 2	mm	373
Toe width front	L b	mm	60
Useable toe depth	n L	mm	55
Diameter top plate	d	mm	95
Length toe supported	L 2	mm	205
Length toe exposed	L 1	mm	260
Width	B	mm	200
Cylinder volume	Liter		0,21
Weight	kg		20
ORDER NO.	01 020 105-0		

HYDRAULIC PRESSURE BLOCKS JD

Safe and powerful

WARNING! DANGER OF TILTING WITHOUT HYDRAULIC PRESSURE BLOCK

When lifting manually with four independent jacks, the load can tip over. The danger is even greater when lowering the load as this happens faster than lifting. Tipping the cargo can be the consequence.

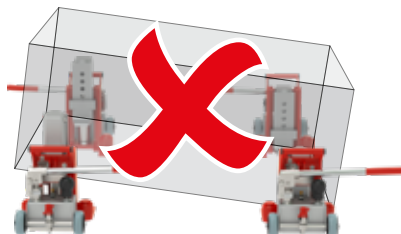

Safety with hydraulic pressure block

Advantages of working with hydraulic pressure block:

- Safer working without danger of tilting
- Time-saving
- One-person-operation

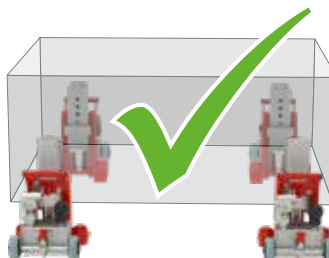

THE FOLLOWING TYPES OF PRESSURE BLOCKS ARE AVAILABLE:

TYPE			JD 40 E+ VS	JD 80 E+ VS
with electrical pump on a cart			yes	yes
Spring return			yes	yes
Dimensions length	l	mm	1 400	1 800
Dimensions width	b	mm	660	800
Dimensions height	h	mm	1 350	1 600
Working pressure		bar	520	520

ORDER NO.

04 400 403-D

04 800 405-D

Customised solutions available on request

i DESCRIPTION

- Synchronized lifting and lowering of multiple jacks. For loads with decentralized center of gravity. Simple and safe.
- Easy operation via push button (remote control).
- All slave-cylinders equipped with 520 bar safety pressure valves. Controls monitor pressure switches with LED indicator preventing any possible overloading.
- Clear and simple control unit, adjustable to control all or individual jacks. Also configurable for using three-point lifting system.
- The complete system is mobile and conveniently mounted on a cart.
- Retracting of the hydraulic jacks also without load (JH 15 - 20 G plus EX).
- Load independent, maintains constant lifting speed.
- Controllable lowering speed.
- Electrical pump JPE 30 and VS-control unit for driving individual lifting devices.
- Oil volume in the system JD 40 E+ VS is sufficient for up to 4 pcs. JH 10 G plus / JH 10 G plus EX / JHS 10. Larger jacks can be operated, but you need to lift twice to reach the full stroke.
- The cylinders in the pressure block are outfitted with spring returns to retract the pistons automatically.



Pressure block JD 40 E+ VS in action

JACKS TO USE WITH PRESSURE BLOCK JD 40 E+ VS	LOAD CAPACITY IN KG
4x JH 6 G plus (full stroke, without spring return)	24 000
4x JHS 5 (full stroke, without spring return)	20 000
4x JH 10 G plus (full stroke, without spring return)	40 000
4x JHS 10/JH 10 G plus ku (full stroke, without spring return)	40 000
4x JH 15 G plus (lift twice to reach full stroke, without spring return)	60 000
4x JH 15 G plus EX (lift twice to reach full stroke, with spring return)	60 000
4x JH 20 G plus (lift twice to reach full stroke, without spring return)	80 000
4x JH 20 G plus EX (lift twice to reach full stroke, with spring return)	80 000

ELECTRICAL PUMPS

JPE

See pages 15-19 for suitable jacks and page 24 for hydraulic hoses.

Powerful and quick

i DESCRIPTION

- Quick connectors with drip free rapid closure valves.
- One oil circuit capable of supplying two or four hydraulic jacks.
- Easily controllable: JPE 30-NVR with precision lowering regulator.
- Sturdy two stage electric pumps available in different versions.



Electric pump JPE 30/4 NVR with 4 jacks in operation.

- Easy handling.
- Includes transport cart for easy and safe transport.
- Also available as 110 V, 50 Hz.
- Maximum safety during operation due to cable remote control.

JPE 30 NVR	
Standard version	
Equipped with 2 hydraulic connections with precise adjustable needle valves and 1 manometer.	

JPE 30/4 NVR	
Extended version	
Equipped with 4 hydraulic connections, each equipped with precise adjustable needle valves and 1 manometer.	

Recommendation: If lifting one side of a load with 2 jacks use electrical pump type JPE, external manual pump JP 26 or air hydraulic pump JPL 15 (see page 23).



ELECTRICAL PUMPS WITHOUT HOSES

TYPE		JPE 20/2	JPE 30 NVR	JPE 30/4 NVR
Oil volume complete/usable	L	5/3,7	7,6/4,8	7,6/4,8
Working pressure	bar	520	520	520
Connections	pcs.	2	2	4
Flow rate low pressure	L/min.	2,5 - 7 bar	3,9 - 7 bar	3,9 - 7 bar
Flow rate high pressure	L/min.	0,45 - 520 bar	0,33 - 520 bar	0,33 - 520 bar
Motor facts		230 V, 50 Hz, 5 A	230 V, 50 Hz, 5 A	230 V, 50 Hz, 5 A
Dimensions L x W x H*	mm	420 x 205 x 300	680*(900**) x 330 x 600	680*(900**) x 330 x 600
Total weight with oil	kg	18	38	41
Usable jacks		any hydraulic jacks	any hydraulic jacks	any hydraulic jacks
ORDER NO.		■ 03 200 200-EU	■ 03 300 202-EU	■ 03 300 402-EU

*Without push handle **With push handle

HAND PUMP JP AND AIR HYDRAULIC PUMP JPL

Light and sturdy



i DESCRIPTION

- Sturdy construction, yet light-weight and easy to handle.
- Pressure limiting valve provides safety against overloading.
- Optimally compatible with our hydraulic jacks.
- JPL 15 with adjustable working pressure.
- Pumps are equipped with integrated quick-lift for faster working.

RECOMMENDED
for use with two jacks



Application with JP 26 and JHS 10

SUITABLE JACKS TO USE WITH A HAND PUMP/AIR HYDRAULIC PUMP

JACKS	JP 26	JPL 15
JH 6 G plus	2 x	2 x
JH 10 G plus / G plus ku / G plus EX	2 x	2 x
JH 15 G plus / G plus EX	2 x	2 x
JH 20 G plus / G plus EX	2 x	2 x
JH 30 G plus EX	1 x	1 x
JHS 5	2 x	2 x
JHS 10	2 x	2 x
JHS 10 ku	2 x	2 x



HYDRAULIC HAND PUMPS

AIR HYDRAULIC PUMPS

TYPE		■ JP 26	■ JPL 15
Oil volume complete/usable	L	2,3/2,2	1,5/1,5
Working pressure	bar	520	0-700**
Flow rate without load	L/ min	-	1,07
Flow rate with load	L/ min	-	0,18
Air connection	bar	-	7-14
Flow rate per stroke	L	0,0132 (0-14 bar)/0,0023 (14-520 bar)	
Connections	pcs.	2	2
Dimensions L x W x H	mm	770 x 169* x 175	380 x 136 x 185
Weight	kg	14	9

ORDER NO.

■ 02 260 000-P

■ 02 150 000-PL

*Width foot plate **adjustable

USEFUL ACCESSORIES

For hydraulic jacks and pumps



	DIMENSIONS	CATALOGUE PAGE	ORDER NO.
01. Manometer for pumps	Ø 63 mm	22-23	94 040 024-E
02. Handle for JH 10 G plus ku and 6/10 G plus To screw on attachment – for jacks	H x W x L mm 110 x 125 x 55	16	91 106 260-B
03. Plug-on manometer For pressure testing or pressure monitoring jacks	Ø 63 mm	15-17	94 001 024-B
04. Assembly of hollow piston with spring return Re-fitting of hydraulic jacks type JH 15 G Plus Re-fitting of hydraulic jacks type JH 20 G Plus	Ø 60 mm Ø 70 mm	17 17	91 156 457-B 91 206 457-B
05. Special toe for ISO-containers For JH 6 G plus For JH 10 G plus For JH 15 G plus	87 x 80 x 90 mm 90 x 85 x 100 mm 98 x 110 x 110 mm	16 17 17	91 999 060-B 91 999 100-B 91 999 150-B
06. Adapter for hose extension JS All hoses	120 mm	24	15 999 001-NN

HYDRAULIC HOSES FOR OUR HAND PUMP, AIR HYDRAULIC PUMP, AND ELECTRICAL PUMPS:

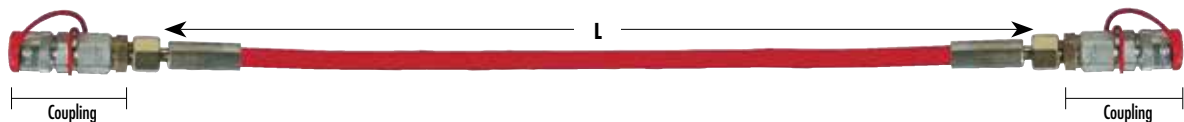

Hydraulic hose (safety factor 4:1), max. working pressure 700 bar, oil-filled, ready for use

TYPE		JS 2	JS 3	JS 4	JS 6	JS ...
Drip free couplings	no.	2	2	2	2	2
Length	L = mm	2 000	3 000	4 000	6 000	variable*

ORDER NO. ■ 15 200 002-0 ■ 15 300 002-0 ■ 15 400 002-0 ■ 15 600 002-0 ■ 15 ...-002**

*available up to 15000 mm **... = ...enter L in cm

» TRANSPORT-TROLLEYS

 Technical drawings of the respective devices can be found at jung-hebetechnik.de

Move safely.

INNOVATIVE

Optimal capacity and weight ratio due to innovative construction.

PRACTICAL

Steering rod with handle, from 6 t with towing eye.

OPTIMAL STEERING

Steerable trolley equipped with ball bearing supported turntable.

SAFELY LOADED

Steel clasps on steerable trolleys JL 12 K, JL 14 K, JLB 16 S, JLB 24 S, JLB 15 G, JLB 20 G, JLB 30 G, JLB 40 H, JLB 60 H and JL 80 H for easy loading and unloading from/into vehicles.

HIGH-QUALITY

High quality castors with precision ball bearings and extremely durable coating. Series K and G with aluminium core for reduced weight.

DIRECTIONAL STABILITY

Connecting bars guarantee alignment of castors even in curves, models 6 metric tons and up with joint.

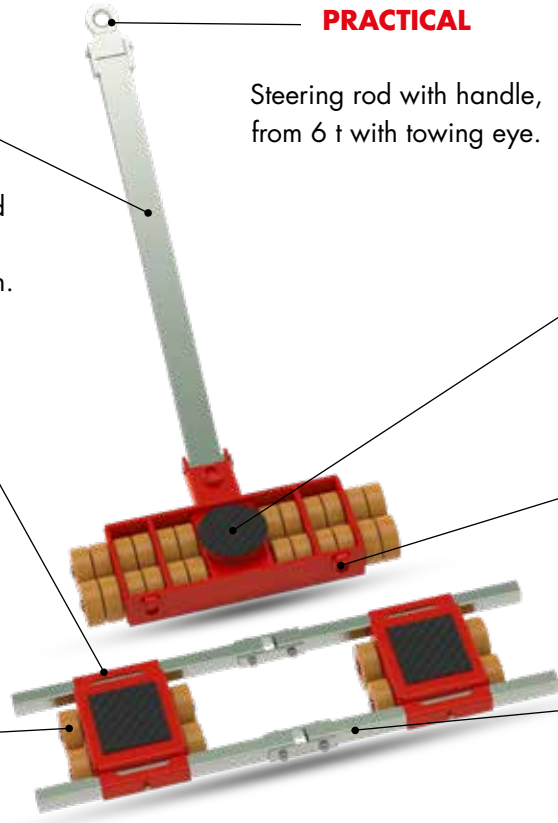

JUNG
High quality products

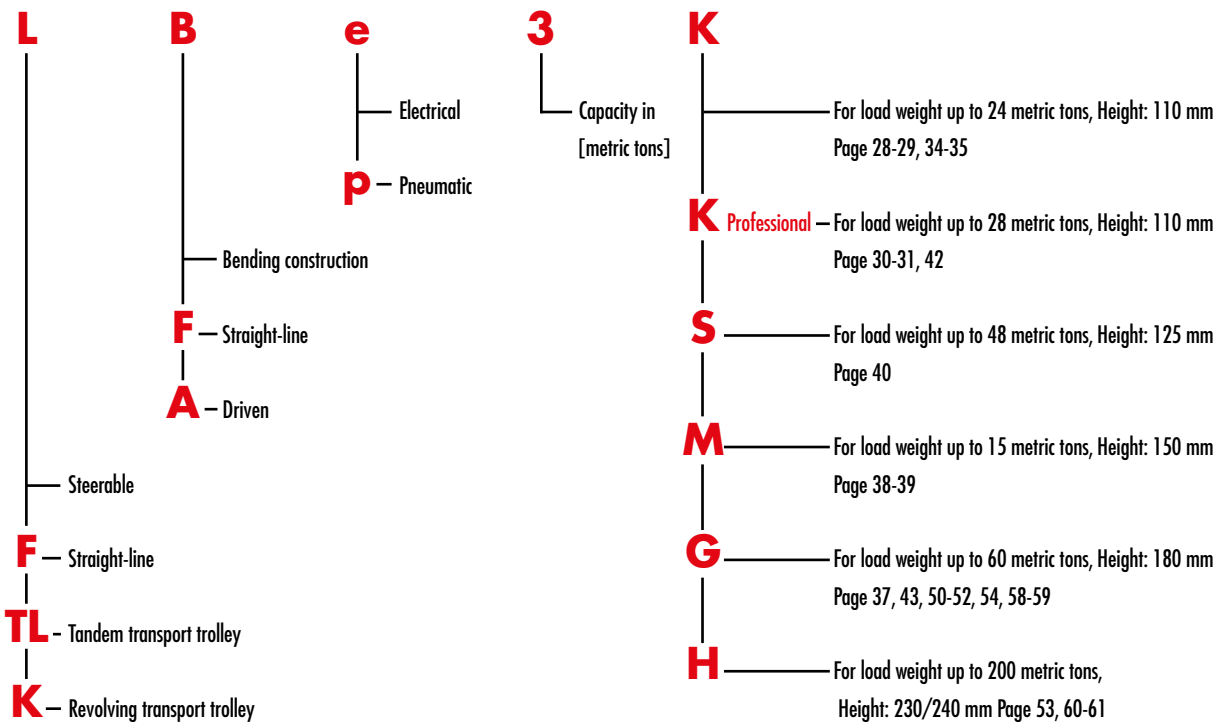



JUNG
L O O L

JUST MOVE.

Ergonomic. Effort-saving. Efficient.



TRANSPORT TROLLEYS

SERIES K

For loads up to 24 metric tons, height: 110 mm

i DESCRIPTION

- Equipped with highest quality castors as standard.
- Reduced weight due to advanced construction of load cassettes.
- Non-marking support wheels.
- The K-series towing bars are also available with a removable handle. The removable handle is also available as a re-fitting set.
- All transport trolleys are ready for use: The steerable transport trolley is fitted with a ball bearing supported turntable and a handlebar. The adjustable-width transport trolley consists of two transport units and connecting bar.
- The load capacity specifications refer to a maximum speed of 2 km/h.



Loads up to		6 t		12 t	
TYPE		JLB 3 K	JFB 3 K	JLB 6 K	JFB 6 K
Load capacity	kg	3 000	2 x 1 500	6 000	2 x 3 000
Number of castors	Pieces	4	2 x 2	8	2 x 4
Castor dimensions	Ø x l mm	85 x 85	85 x 85	85 x 85	85 x 85
Height	mm	110	110	110	110
Supporting surface per cassette	E x F mm		120 x 80		170 x 170
Cassette dimensions	L2 x B2 mm		190 x 115		325 x 200
Connecting bar with joint	Length mm		1 000**		1 230
Cassettes adjustable from - to	G - H mm		125-880		400-1 030
Supporting surface of turntable	Ø C mm	150		150	
Dimensions	L1 x B1 mm	225 x 280		445 x 590	
Handlebar with pulling eye	Length mm	990*		1 210	
Weight JUWATHAN®plus	kg	12	11	34	25

ORDER NO. ■ 07 031 085-V ■ 08 031 085-V ■ 07 061 085-V ■ 08 061 085-V

*JLB 3 K steering bar without pulling eye **JFB 3 K connecting bar without joint



Castors with ball bearings guarantee easy movement.

▶ **EXAMPLE FOR LOAD DISTRIBUTION**
12 metric tons trolley combination:

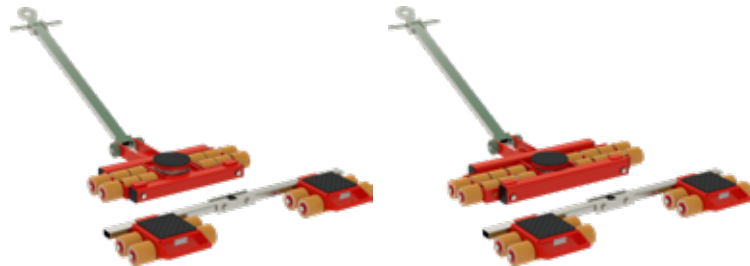
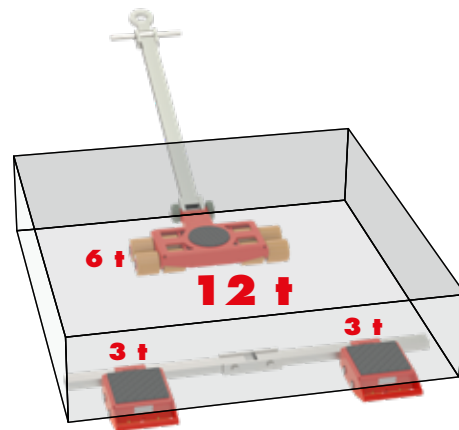

Loads up to			18 t		24 t	
TYPE			JL 9 K	JFB 9 K	JL 12 K	JFB 12 K
Load capacity	kg		9 000	2 x 4 500	12 000	2 x 6 000
Number of castors	Pieces		12	2 x 6	16	2 x 8
Castor dimensions	Ø x l	mm	85 x 85	85 x 85	85 x 85	85 x 85
Height	mm		110	110	110	110
Supporting surface per cassette	E x F	mm		170 x 170		170 x 170
Cassette dimensions	L2 x B2	mm		325 x 390		325 x 390
Connecting bar with joint	Length	mm		1 230		1 230
Cassettes adjustable from - to	G - H	mm		400-1 030		400-1 030
Supporting surface of turnable	Ø C	mm	170		170	
Dimensions	L1 x B1	mm	580 x 820		580 x 1 000	
Handlebar with pulling eye	Length	mm	1 210		1 210	
Weight JUWathan®plus	kg		49	31	62	34
ORDER NO.			■ 07 090 085-V	■ 08 091 085-V	■ 07 120 085-V	■ 08 121 085-V

TRANSPORT TROLLEYS

SERIES K PROFESSIONAL

For loads up to 28 metric tons, Height: 110 mm

i DESCRIPTION

■ The double castor design results in dramatically easier steering due to reduced friction forces in curves. The much lower friction resistance also causes the trolleys on the rear axis to follow in a true to track course.

■ Non-marking support wheels.

■ Higher capacity with professional castors, at same dimension as series K trolleys.

■ The series K handle bars are now also available with a removable handle, which is also available as a re-fitting set.

■ Because of the professional castors you need 30% less power for steering.

■ All transport trolleys are ready for use: the steerable transport trolley is fitted with a ball bearing supported turntable and a handlebar. The adjustable-width transport trolley consists of two transport units and connecting bar.

■ The load capacity specifications refer to a maximum speed of 2 km/h.



Loads up to			14 t		20 t	
TYPE			JLB 7 K	JFB 7 K	JL 10 K	JFB 10 K
Load capacity	kg		7 000	2 x 3 500	10 000	2 x 5 000
Number of twin castors	Pieces		8	2 x 4	12	2 x 6
Castor dimensions	Ø x l	mm	85 x 85	85 x 85	85 x 85	85 x 85
Height	mm		110	110	110	110
Supporting surface per cassette	E x F	mm		170 x 170		170 x 170
Cassette dimensions	L2 x B2	mm		325 x 200		325 x 390
Connecting bar with joint	Length	mm		1 230		1 230
Cassettes adjustable from - to	G - H	mm		400-1 030		400-1 030
Supporting surface of turntable	Ø C	mm	150		170	
Dimensions	L1 x B1	mm	445 x 590		580 x 820	
Handlebar with pulling eye	Length	mm	1 210		1 210	
Weight Professional	kg		35	27	56	35
ORDER NO.			■ 07 071 085-D	■ 08 071 085-D	■ 07 100 085-D	■ 08 101 085-D

TESTED

 according to technical
 regulation ANSI/ASME
 (USA)

Castors with ball bearings guarantee easy movement.

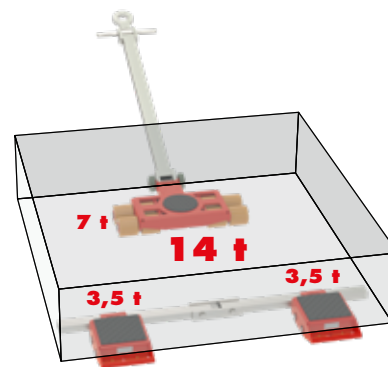
EXAMPLE FOR LOAD DISTRIBUTION
14 metric tons trolley combination:

Loads up to

28 t

TYPE			JL 14 K	JFB 14 K
Load capacity	kg		14 000	2 x 7 000
Number of twin castors	Pieces		16	2 x 8
Castor dimensions	Ø x l	mm	85 x 85	85 x 85
Height		mm	110	110
Supporting surface per cassette	E x F	mm		170 x 170
Cassette dimensions	L2 x B2	mm		325 x 390
Connecting bar with joint	Length	mm		1 230
Cassettes adjustable from - to	G - H	mm		400-1 030
Supporting surface of turnable	Ø C	mm	170	
Dimensions	L1 x B1	mm	580 x 1 000	
Handlebar with pulling eye	Length	mm	1 210	
Weight Professional	kg		65	38

ORDER NO.
07 140 085-D
08 141 085-D

MOVE **FLEXIBLY.**

Agile. Easy. Efficient.





JUNG

REVOLVING TRANSPORT TROLLEYS JKB

For loads up to 12 metric tons, height 110* mm

i DESCRIPTION

- Optional connecting bars can be fixed without tools by clamping down on adapter.
- High load capacity at low weight.
- Bearing supported swiveling castors allow 360° maneuverability.
- Mix and match revolving trolleys with transport trolleys: JKB 2 to JKB 8 have same height as transport trolleys series K.
- All products are also available in a set of two with price advantage.
- In addition, all the trolleys have a platform center hole to allow attachment to the load.
- Using the slots in the platform, the trolleys JKB 4 - 8 can be affixed to the load with standard lashing belts.
- Pulling handle and connecting bars available as accessories (see pages 66-67).
- Unrivalled: The narrow castors reduce rolling and turning resistance to a minimum.
- For choosing the adequate revolving trolley we recommend a load of two-third of the maximum capacity. This will be the most advantageous compromise between payload, ergonomics and handling of the devices.
- The load capacity specifications refer to a maximum speed of 2 km/h.



Loads up to		2 t		4 t	
TYPE		■ JKB 2 K		■ JKB 2 SET	
Consist of		1 x JKB 2 K		2 x JKB 2 K	
Load capacity	kg	2 000		2 x 2 000	
Number of castors	Pieces	6		2 x 6	
Castor dimensions	Ø x l mm	85 x 43		85 x 43	
Height	mm	110*		110*	
Supporting surface per cassette	Ø C mm	150		150	
Cassette dimensions	L1 x B1 mm	528 x 495		528 x 495	
Weight JUWAmid	kg	20		40	
ORDER NO. with JUWAmid		■ 14 020 085-P		■ 14 020 085-D	
ORDER NO. with JUWathan®		■ 14 020 085-VU		■ 14 020 085-DVU	

*Due to technical changes, there may be tolerances of up to + 4.5 mm in the installation height since 2014.

All revolving transport trolleys
are also available with white

POLYAMIDE-WHEELS

Upgrade item number: 14 030 091-P

TESTED

according to technical
regulation ANSI/ASME
(USA)



Revolving trolley JKB in action.

EXAMPLE FOR LOAD DISTRIBUTION 12 metric tons trolley combination:

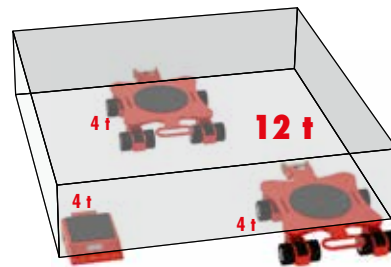

Loads up to		4 t	8 t	6 t	12 t
TYPE		JKB 4 K	JKB 4 SET	JKB 6 K	JKB 6 SET
Consist of		1 x JKB 4 K	2 x JKB 4 K	1 x JKB 6 K	2 x JKB 6 K
Load capacity	kg	4 000	2 x 4 000	6 000	2 x 6 000
Number of castors	Pieces	12	2 x 12	16	2 x 16
Castor dimensions	Ø x l mm	85 x 43	85 x 43	85 x 43	85 x 43
Height	mm	110*	110*	110*	110*
Supporting surface per cassette	Ø C mm	250	250	250	250
Cassette dimensions	L1 x B1 mm	690 x 475	690 x 475	675 x 525	675 x 525
Weight JUWAmid	kg	38	76	41	82
ORDER NO. with JUWAmid		■ 14 041 085-P	■ 14 041 085-D	■ 14 061 085-P	■ 14 061 085-D
ORDER NO. with JUWathan®		■ 14 041 085-VU	■ 14 041 085-DVU	■ 14 061 085-VU	■ 14 061 085-DVU

*Due to technical changes, there may be tolerances of up to + 4.5 mm in the installation height since 2014.

REVOLVING TRANSPORT TROLLEYS JKB

For loads up to 28 t metric tons, height 110* mm/180 mm

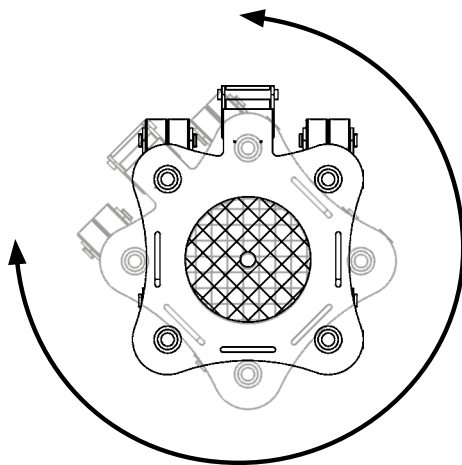

360° rotation in all directions



Revolving trolley JKB in action

For information on matching
ACCESORIES
see Pages 66-67.



Loads up to		8 t	16 t
TYPE		JKB 8 K	JKB 8 SET
Consist of		1 x JKB 8 K	2 x JKB 8 K
Load capacity	kg	8 000	2 x 8 000
Number of castors	Pieces	20	2 x 20
Castor dimensions	Ø x l mm	85 x 43	85 x 43
Height	mm	110*	110*
Supporting surface per cassette	Ø C mm	250	250
Cassette dimensions	L1 x B1 mm	895 x 740	895 x 740
Weight JUWAmid	kg	64	128
ORDER NO. with JUWAmid		■ 14 080 085-P	■ 14 080 085-D
ORDER NO. with JUWathan®		■ 14 080 085-VU	■ 14 080 085-DVU

*Due to technical changes, there may be tolerances of up to + 4.5 mm in the installation height since 2014.

All revolving transport trolleys are also available with white

POLYAMIDE-WHEELS

Upgrade item number: 14 030 091-P

TESTED

according to technical regulation ANSI/ASME (USA)

i DESCRIPTION

- JKB 10 G/JKB 14 G have same height as transport trolleys series G.
- Connecting bars as standard 2000 mm, can be offered up to 3 m length.
- High load capacity at low weight.
- Bearing supported swiveling castors allow 360° maneuverability.
- All products are also available in a set of two with price advantage.
- In addition, all the trolleys have a platform center hole to allow attachment to the load.
- Unrivalled: The narrow castors reduce rolling and turning resistance to a minimum.
- Pulling handle and connecting bars available as accessories (see pages 66-67).
- For choosing the adequate revolving trolley we recommend a load of two-third of the maximum capacity. This will be the most advantageous compromise between payload, ergonomics and handling of the devices.
- The load capacity specifications refer to a maximum speed of 2 km/h.

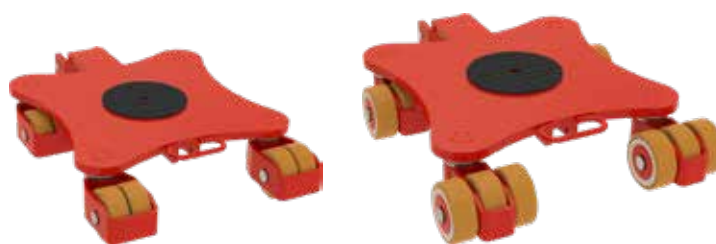

Loads up to		10 t	20 t	14 t	28 t
TYPE		■ JKB 10 G	■ JKB 10 SET	■ JKB 14 G	■ JKB 14 SET
Consist of		1 x JKB 10 G	2 x JKB 10 G	1 x JKB 14 G	2 x JKB 14 G
Load capacity	kg	10 000	2 x 10 000	14 000	2 x 14 000
Number of castors	Pieces	8	2 x 8	12	2 x 12
Castor dimensions	Ø x l mm	140 x 59	140 x 59	140 x 59	140 x 59
Height	mm	180	180	180	180
Supporting surface per cassette	Ø C mm	250	250	250	250
Cassette dimensions	L1 x B1 mm	975 x 665	975 x 665	975 x 720	975 x 720
Weight JUWathan®	kg	127	254	148	296

ORDER NO. with JUWathan®

■ 14 101 140-VU

■ 14 101 140-DVU

■ 14 140 140-VU

■ 14 140 140-DVU

MULTI-PURPOSE TROLLEYS SERIES M

For loads up to 15 metric tons, height 150 mm

i DESCRIPTION

- Combines leading swiveling castors with trailing rigid castors. Swiveling lead-castors make steering easier by up to 80%.
- Ergonomic: Reduces handling effort for user.
- Better directional stability on long straight-line paths with trailing rigid castors.
- Trolleys can be used as steerable, adjustable or tandem trolley.
- Low installation height. Low weight.
- Extreme maneuverable with thrust bearing supported, anti-slip turntable.
- Ideal for transporting loads on slalom paths including 90° true-to-course straightline, turning and sideways maneuvering.
- Floor protective, non-marking coating.
- Each trolley can be used for either steerable or straight-line movements.
- An additional pulling handle for steering of rear-trailing trolleys for tighter turning radius is included in the set
- The load capacity specifications refer to a maximum speed of 2 km/h.

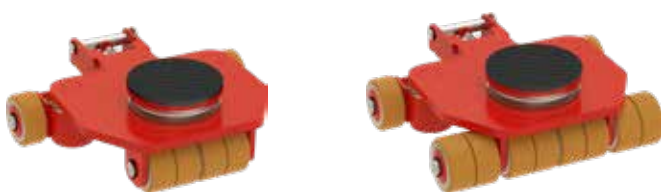

Loads up to		3,5 t	5 t
TYPE		JLF 3,5	JLF 5
Load capacity	kg	3 500	5 000
Number of castors / twin castors	Pieces	4/2	4/4
Castor dimensions	mm	85 x 43	85 x 43
Height	mm	150	150
Supporting surface per cassette	Ø C mm	150	150
Dimensions	L1 x B1 mm	410 x 420	410 x 420
Handlebar with pulling eye		-	-
Connecting bar		-	-
Weight JUWathan®plus	kg	25	28

ORDER NO. ■ 16 035 085-D ■ 16 050 085-D

Registered design EU No. 002267487 - 001 European patent No. 2 662 261 B1

TESTED
according to technical
regulation ANSI/ASME
(USA)



Example as tandem transport trolley



Example as adjustable trolley



Loads up to

12 t

15 t

TYPE		JLF SET 12	JLF SET 15
Load capacity	kg	1 x 5 000 + 2 x 3 500	3 x 5 000
Number of castors/twin castors	Pieces	3 x 4/2 x 2 + 1 x 4	3 x 4/3 x 4
Castor dimensions	mm	85 x 43	85 x 43
Height	mm	150	150
Supporting surface per cassette	Ø C mm	150	150
Dimensions	L1 x B1 mm	410 x 420	410 x 420
Handlebar with pulling eye	L mm	1 210	1 210
Connecting bar	Ø x L mm	20 x 1 200	20 x 1 200
Weight JUWathan®plus	kg	89	95
ORDER NO.		16 120 085-D	16 150 085-D

TRANSPORT TROLLEYS

SERIES S



For loads up to 48 metric tons, height 125 mm

i DESCRIPTION

■ Pivoting roller cassettes within the frame (except for JLB 16 S) assure even pressure distribution across all castors and across the floor.

■ Very low height at only 125 mm, with high capacity and low own weight.

■ All transport trolleys are ready for use: the steerable transport trolley is fitted with a ball bearing supported turntable and a handlebar (as shown in picture). The adjustable-width transport trolley consists of two transport units and connecting bars.

■ Slim castor design (60 mm fitting length) results in easier steering due to reduced friction forces also in curves.

■ The load capacity specifications refer to a maximum speed of 2 km/h.



Loads up to		32 t		48 t	
TYPE		JLB 16 S	JFB 16 S	JLB 24 S	JFB 24 S
Load capacity	kg	16 000	2 x 8 000	24 000	2 x 12 000
Number of castors	Stück	16	2 x 8	24	2 x 12
Castor dimensions	Ø x l mm	90 x 60	90 x 60	90 x 60	90 x 60
Height	mm	125	125	125	125
Supporting surface per cassette	E x F mm		200 x 220		200 x 220
Cassette dimensions	L2 x B2 mm		370 x 330		370 x 465
Connecting bar with joint	Length mm		2 x 1 540		2 x 1 540
Cassettes adjustable from - to	G - H mm		540-1 300		660-1 300
Supporting surface of turntable	Ø C mm	215		215	
Dimensions	L1 x B1 mm	580 x 815		580 x 1 165	
Handlebar with pulling eye	mm	1 230		1 480	
Weight JUWAtan®	kg	82	74	124	78
ORDER NO. with JUWAtan®		■ 05 161 090-V	■ 06 161 090-V	■ 05 242 090-V	■ 06 242 090-V
ORDER NO. with steel castors		■ 05 161 090-S	■ 06 161 090-S	■ 05 242 090-S	■ 06 242 090-S

PROFESSIONALLY MOVED.

Safe. Simple. Flexible.

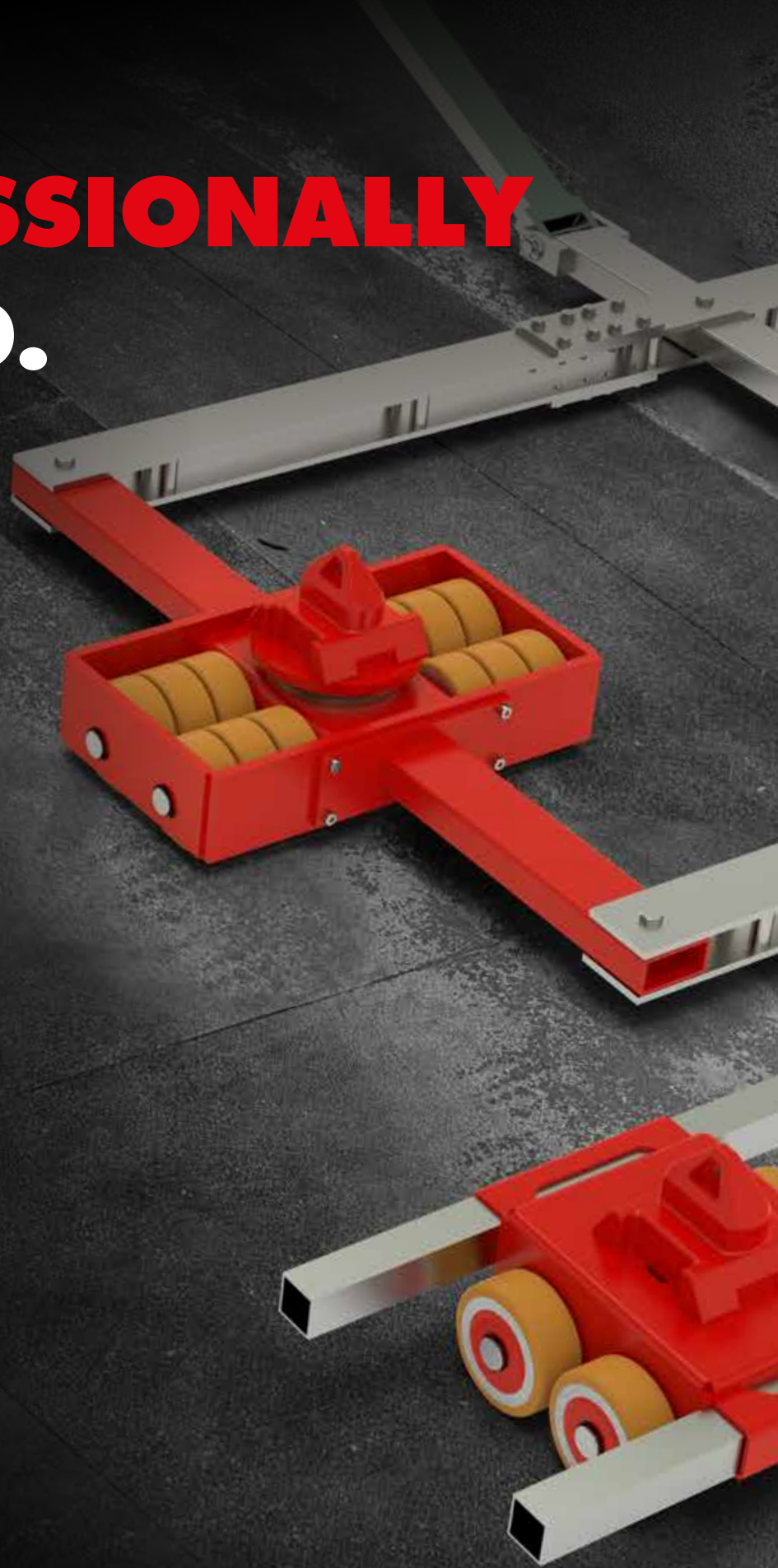

JUNG
HEINRICH

TANDEM TROLLEYS SERIES K

For loads up to 14 metric tons, height 110 mm

i DESCRIPTION

■ Tandem transport trolley for loads with no leading or trailing edge center support.

■ The double castors design results in dramatically easier steering due to reduced friction forces in curves. The much lower friction resistance also causes the castors on the rear axis follow in a true to track course.

■ Non-marking support wheels.

■ Ready for use: delivery includes 2 steering units, 2 towing bars and 1 set of connecting rods.

■ Multi-purpose use: also usable as two single trolleys, each with half of the combined load capacity. No additional accessories needed.

■ The load capacity specifications refer to a maximum speed of 2 km/h.

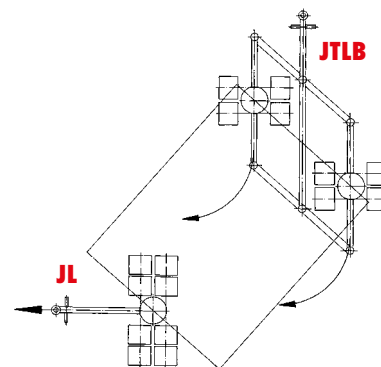

Example: For short radius curves steering possible up to 45°.



Loads up to		6 t		14 t	
TYPE		■ JTLB 6 K		■ JTLB 14 K	
Load capacity	kg	6 000		14 000	
Number of twin castors	Pieces	8		16	
Castor dimensions	Ø x l mm	85 x 85		85 x 85	
Height	mm	110		110	
Cassette dimensions	L2 x B2 mm	600 x 280		1 000 x 590	
Supporting surface per cassette	Ø C mm	150		150	
Connecting bar*	E mm	1 000		1 400	
Adjustable from - to Vmin. - Vmax.	mm	560-960		660-1 340	
Adjustable		5 x		5 x	
Total length/width	L1 x B1 mm	770 x 1 240		1 105 x 1 924	
Handlebar with pulling eye	Length mm	990**		1 210	
Weight Professional	kg	47		102	

ORDER NO. Professional

■ 12 061 085-D

■ 12 121 085-D

*other lengths available on request **JTLB 6 without pulling eye

TANDEM TROLLEYS

SERIES G PROFESSIONAL

For loads up to 30 metric tons, height 180 mm

i DESCRIPTION

- Big castors Ø 140 mm x width 59 mm provide optimal rolling characteristics on uneven surfaces and rough pavements.
- Safely overcomes small ledges, cracks in the concrete and countersunk rail tracks.
- Custom solutions available.
- Multi-purpose use: also usable as two single trolleys, each with half of the combined load capacity. No additional accessories needed. Comes with two towing bars.
- The load capacity specifications refer to a maximum speed of 2 km/h.

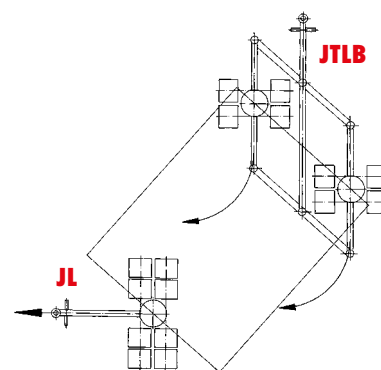

Example: For short radius curves steering possible up to 45°.

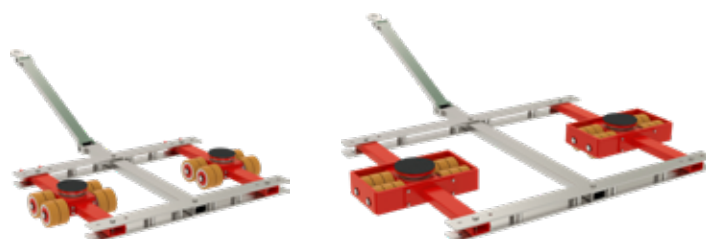

Loads up to		20 t	30 t
TYPE		JTL 20 G	JTLB 30 G
Load capacity	kg	20 000	30 000
Number of castors	Pieces	16	24
Castor dimensions	Ø x l mm	140 x 59	140 x 59
Height	mm	180	180
Supporting surface of turntable	Ø C mm	170	215
Cassette dimensions	L2 x B2 mm	1 020 x 440	1 380 x 610
Width of track and connection rod*	E mm	1 330	1 700
Adjustable from - to Vmin. - Vmax.	mm	900-1 230	1 270-1 600
Adjustable		3 x	3 x
Dimensions	L1 x B1 mm	1 260 x 1 670	1 620 x 2 200
Handlebar with pulling eye	Length mm	1 230	1 230
Weight JUWATHan®plus	kg	168	283

ORDER NO. with JUWATHan®plus

■ 12 202 140-V

■ 12 302 140-V2

*other lengths available on request

TANDEM TROLLEYS "WELD-ON CONE"

For transporting containers up to 28 metric tons, height 170 mm

i DESCRIPTION

- „Weld-on Cone“ version for indoor container transport on smooth floors includes turntables fitted with cones and 2-parts container-wide connecting bars fixed length 2.26 m; also including a pulling handle with towing eye.
- Safe transport of containers.
- Containers can be moved with extremely low installation height.
- Form-fitting-hold between the trolley and the containers (Weld-on Cone System).
- Compatible with all ISO-containers.
- The load capacity specifications refer to a maximum speed of 2 km/h.



Weld-on Cone



Twistlock

CONVERSION
to a twistlock system
possible.

For information
on matching
ACCESSORIES
see **Pages**
66-67.

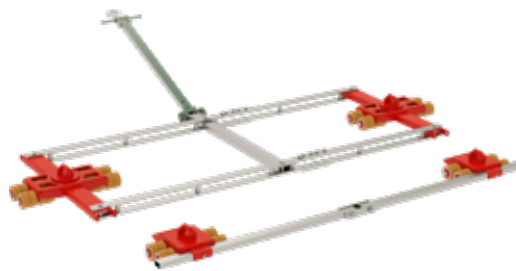

„Weld-on Cone“ system for Series K
Please refer to pages 28-29, 34-35, 42 for technical details

TYPE		■ JTLB 14 K WOC		■ JFB 14 K WOC	
Height	h1	mm	110		110
Total height	h2	mm	170		170
ISO-length	V	mm	2260		2260
Dimensions steerable	L1 x B1	mm	1120 x 2850		-
Dimensions straight-line	L2 x B2	mm	-		325 x 2650
ORDER NO.		■ 12 121 085-WZ		■ 08 141 085-WOC	

TANDEM TROLLEYS

TWISTLOCK

For transporting containers up to 60 metric tons, height 300 mm

i DESCRIPTION

- “Twistlock” version for outdoor transport for use on pavement includes turntables fitted with “Twistlock” to secure containers to transport trolleys. Including 2-parts connecting bars fixed length 2.26 m and pulling handle with towing eye.
- Containers can be moved with extremely low installation height.
- Lock-to-hold mechanism between the trolley and the containers (Twistlock).
- Compatible with all ISO-containers.
- Safe transport of containers.
- The load capacity specifications refer to a maximum speed of 2 km/h.



Also
AVAILABLE
with extended track rods
on request.

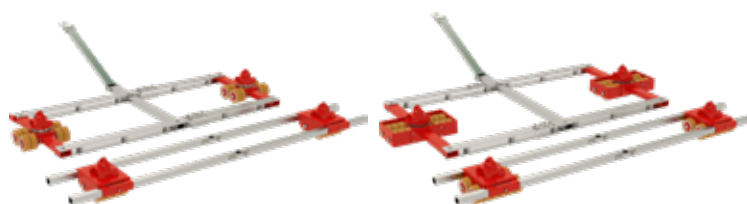

Twistlock system for Series G
Please refer to page 35, 38-39 for technical details

TYPE			JTL 20 G TL	JFB 20 G TL	JTLB 30 G TL	JFB 30 G TL
Height	h1	mm	215	215	215	215
Total height	h2	mm	300	300	300	300
ISO-length	V	mm	2 260	2 260	2 260	2 260
Dimensions steerable	L1 x B1	mm	1 260 x 2 700	-	1 620 x 2 870	-
Dimensions straight-line	L2 x B2	mm	-	460 x 3 000	-	460 x 3 000
ORDER NO.			■ 12 202 140-TL	■ 10 202 140-TL	■ 12 302 140-TL	■ 10 302 140-TL

CONTAINER-TRAVERSE

With Twistlock-fitting up to 36 metric tons, height 260 mm

! Additional mounting hardware/drill holes for the traverse are offered to suit the specific application.

i DESCRIPTION

- Safe transport of ISO-containers and special containers up to 36 metric tons.
- Containers can be moved with extremely low installation height.
- Assembled in two parts for easy handling and storage.
- Compatible with all ISO containers.
- Lockable twistlock version to ISO dimension 2.26 m (not adjustable).
- Optionally a trapezium drawbar can be adapted.
- The dimension of the traverse is within the container contour.
- The load is firmly connected to the chassis and can be completely loaded.
- Installation height of the crossbar: 80 mm.



CONTAINER-TRAVERSE SINGLE
ORDER NO.: 92 000 226-T1



CONTAINER-TRAVERSE WITH DRAWBAR
ORDER NO.: 92 000 226-T2

POSSIBLE COMBINATIONS:

Steerable trolleys	Trolleys	TOTAL LOAD CAPACITY IN KG*
2 x JKB 4 K	1 x JFB 7 K	15 000
2 x JKB 6 K	1 x JFB 10 K	22 000
2 x JKB 7,5 K	1 x JFB 14 K	29 000
1 x JTLB 14 K	1 x JFB 14 K	28 000
2 x JKB 10 G	1 x JFB 20 G	36 000
2 x JKB 14 G	1 x JFB 30 G	36 000
2 x JLF 5	2 x JLF 5	20 000
1 x JLA-e 15/30 G	1 x JFB 15 G	30 000
1 x JLA-e 25/50 H	1 x JFB 25 G	36 000
1 x JTL 20 G	1 x JFB 20 G	36 000
1 x JTLB 30 G	1 x JFB 30 G	36 000

*Load must rest on the crossbar as a surface load

POSSIBLE COMBINATIONS CONTAINER-TRAVERSE:



JFB 30 G with traverse

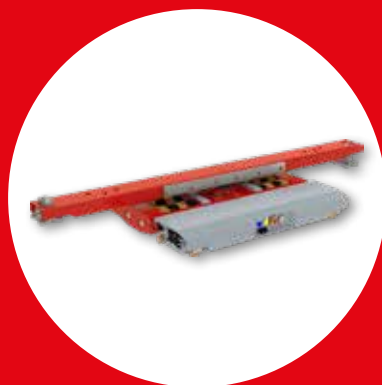

JLA-e 15/30 G with traverse



JKB 10 G with traverse

EXAMPLE USAGE CONTAINER-TRAVERSE

Example: Container traverse suitable for standard tandem steering systems. The traverse is firmly connected to the turntables by screwing and thus forms a secure transport unit.



JACK WITH SPECIAL TOE FOR CONTAINERS

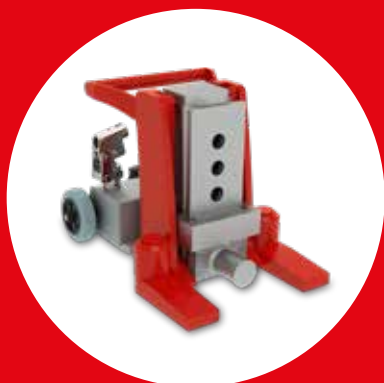

Hydraulic jack with special toe for containers:

The special toe fits in the container corners for safe lifting of ISO containers, can also be upgraded. Available for all hydraulic jacks series JH-G plus and JHS 10 ku.

MOVE **INNOVATIVELY.**

Flexible. Driven. Efficient.



JUNG



TROLLEY

AIR-POWERED

For loads up to 30 metric tons, height 180 mm

i DESCRIPTION

- Ecofriendly, uses only compressed air.
- Spare a towing vehicle.
- Low maintenance propulsion system.
- No need to charge any batteries.
- 360° maneuverable.
- Compatible with G-series transport trolleys (page 58-59).
- All hoses are detachable for compact and easy transport.
- Quick set up. Connect air supply hose and go.
- Requires standard shop air connection with 8 bar (116 psi) and air volume of 1500 L/min (25 L/s) or (53 SCFM).
- Infinitely variable speed and direction.
- Length of the air hose: 4 m
- Model JLA-p 15 / 30 G includes the trolley and remote control unit.
- Two air motors are independently controllable by two joysticks.
- Maneuverability: Forward, reverse, in place turning.
- Higher capacities available on request.



Loads up to

15 t

TYPE		■ JLA-P 15 / 30 G	
Load capacity	kg	15 000	
Pulling capacity	kg	30 000	
Number of castors	Pieces	16	
Castor dimensions	Ø x l mm	140 x 59	
Height	mm	180	
Supporting surface per cassette	Ø C mm	215	
Dimensions	L1 x B1 mm	650 x 1 000	
Weight without control box	kg	175	
Air consumption	L/sec.	25	
Required air pressure	bar	8	

ORDER NO.

■ 22 150 140-V

TROLLEY SETS AIR-POWERED



i TROLLEY SETS

Set 2 includes:

- JLA-p 15/30 G includes control unit
- Hose cart complete with hose reel
- 30 m air supply hose with Ø 19 mm
- 1 Liter oil for pneumatic motors
- 400 ml chain spray (not overseas)

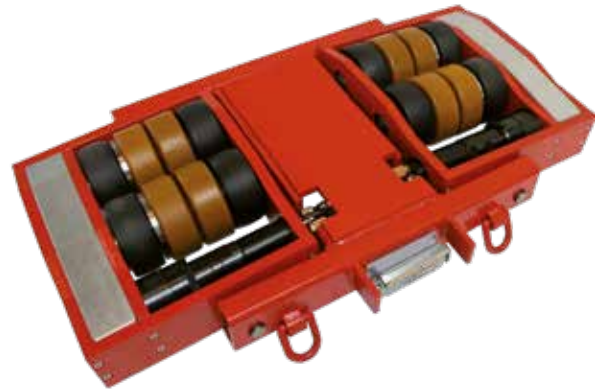

Underside view of JLA-p trolley

Set 3 additionally includes:

- Transport trolley JFB 15 G (see page 58)



JLA-p Set in action



JLA SETS

TYPE	JLA-P SET 2	JLA-P SET 3
JLA-p incl. control box	1 x	1 x
Hose length/diameter	30 m/19 mm	30 m/19 mm
Cart + oil + chain spray	1 x	1 x
JFB 15 G	-	1 x
ORDER NO.	22 150 140-VP2	22 150 140-VP3

TROLLEYS

ELECTRIC-POWERED

For loads up to 50 metric tons, height 180 mm/230 mm



ADDITIONAL SAFETY

The new generation of drives prevents rolling away even when turned off.

COMPACT CONSTRUCTION

The advanced LiFePo4 cell technology with higher energy density makes a more compact design.

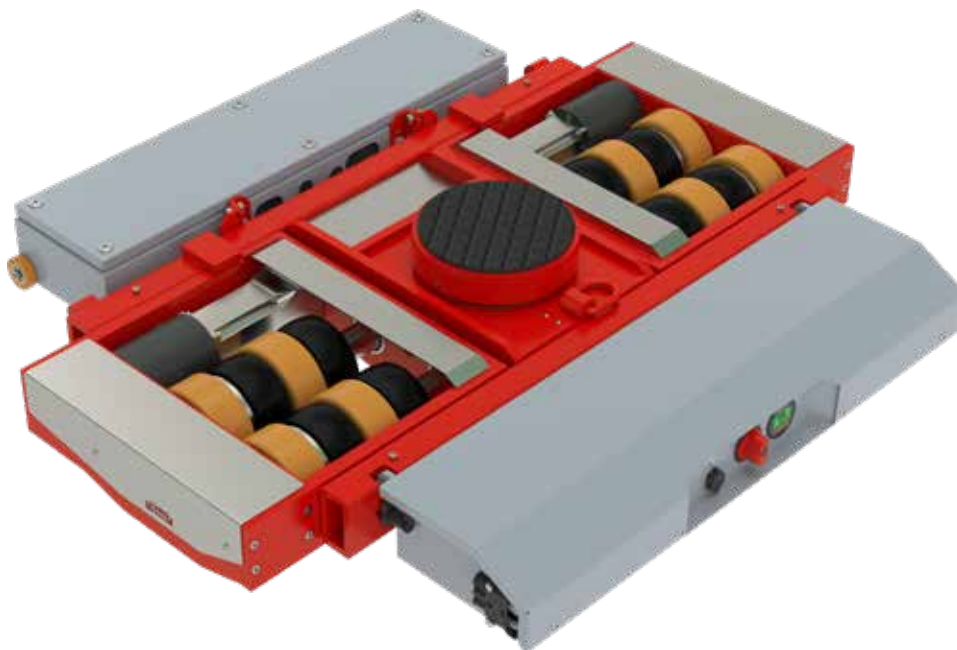

ATTRACTIVE DESIGN

Side cover plates with JUNG lettering provide protection against dirt and offer an attractive design..

NEW BATTERY DISPLAY

It displays various parameters in real time, such as voltage, current power, or the state of charge.

FASTER READY FOR USE

Reduced charging time provided by optimized quick charger.



NEW REMOTE CONTROL

Even more fl exible. Based on 2.4 Ghz, with cable connection socket, one- or two-handed operation, vibration feedback etc.

i DESCRIPTION

- Practical, with battery and handy remote control! The remote control can be switched from two-handed to one-handed operation (flexible left/right). The one-handed operation allows to move the trolley exactly straight ahead.
- Spare a towing vehicle.
- Very compact dimensions.
- Low charging time of 4-5 h; Alternatively high-speed charger = 2-3 h. Available as accessory.
- Batteries are interchangeable.
- High running time (at full load under ideal conditions) by direct-driven motor.
- 360° maneuverable. Infinitely variable speed.
- Compatible with series G (p. 58-59) and series H (p. 60-61). Transport trolleys are not included
- LiFePo4 battery technology.
- A cable remote control is available on request.



Loads up to		12 t		30 t	
TYPE		■ JLA-E 5/12 G		■ JLA-E 15/30 G	
Load capacity	kg	5 000		15 000	
Pulling capacity	kg	12 000		30 000	
Number of castors	Pieces	4		16	
Castor dimensions	Ø x l	mm	140 x 59	mm	140 x 59
Height		mm	180	mm	180
Supporting surface of turntable	Ø C	mm	150	mm	215
Dimensions	L1 x B1	mm	750 x 900	mm	835 x 1215
Weight without battery + controller	kg	146		198	
Weight battery + box	kg	45		45	
Weight charger	kg	2		2	
Speed	m/min	10		6,5	
Operational time	h	4-5		4-5	
Operating mode in acc. with VDE 0530		S1		S3 60%	
Battery and charger	Pieces	1 x		1 x	
Remote control, charger and belt with holder	Pieces	1 x		1 x	

ORDER NO.
■ 22 005 200-G
■ 22 015 200-G

TROLLEYS

ELECTRIC-POWERED

For loads up to 50 metric tons, height 180 mm/230 mm



POWER SUPPLY

- Suitable for JLA-e 5/12 G und 15/30 G
- Cable length to the JLA-e: 10 m
- Cable length to the network: 2 m
- Output voltage DC: 48 V nominal
- Input voltage AC: 100-240 V
- Mains frequency: 50-60 Hz
- Temperature range: -25° C up to + 70° c operational
- Mounted on castors with push handle and cable holder.
- Weight: 18 kg



Loads up to

50 t

TYPE		■ JLA-E 25 / 50 H	
Load capacity	kg		25 000
Pulling capacity	kg		50 000
Number of castors	Pieces		16
Castor dimensions	Ø x l	mm	200 x 83
Height		mm	230
Supporting surface of turnable	Ø C	mm	250
Dimensions	L1 x B1	mm	1 140 x 1 750
Weight without battery + controller	kg		578
Weight battery + box	kg		45
Weight charger	kg		2
Speed	m/min		10
Operational time	h		2-3
Operating mode in acc. with VDE 0530			S3 60%
Battery and charger	Pieces		1 x
Remote control, charger and belt with holder	Pieces		1 x

ORDER NO.

■ 22 025 200-H



i TROLLEY SETS

Set includes:

- Electric-powered trolley.
- High performance accumulator with pulse charging device
- Remote control with battery, charger and belt holder. The remote control can be switched from two-handed to one-handed operation - flexible left/right).
- Adequate transport trolley



Up to 30 metric tons easy to move!



JLA-E SET 3



JLA-E SETS

TYPE		JLA-E SET 1	JLA-E SET 2	JLA-E SET 3
JLA-e		1 x JLA-e 5/12 G	1 x JLA-e 15/30 G	1 x JLA-e 25/50 H
Transport trolley		1 x JFB 7 K (adjusted height)	1 x JFB 15 G	1 x JFB 25 G (adjusted height)
Load capacity adjustable	kg	2 x 3 500	2 x 7 500	2 x 12 500
Number of castors adjustable	Pieces	8	12	20
Height adjustable	mm	180	180	230
Supporting surface cassette	mm	170 x 170	220 x 120	220 x 120
Cassette dimensions	mm	325 x 200	460 x 205	460 x 330
ORDER NO.		■ 22 005 220-G SET	■ 22 015 220-G SET	■ 22 025 220-H SET

TROLLEYS WITH STROKE ELECTRIC-POWERED

For loads up to 30 metric tons, height 180 mm/200 mm

i DESCRIPTION

- Stroke max. 50 mm. The load can be moved in the extended state.
- Practical, with battery and handy remote control. The remote control can be switched from two-handed to one-handed operation (flexible left/right). The one-handed operation allows to move the trolley exactly straight ahead.
- High running time (at full load under ideal conditions) by direct-driven motor.
- Low charging time of 4-5 h; Alternatively high-speed charger = 2-3 h. Available as accessory.
- Spare a towing vehicle
- 360° maneuverable.
- Infinitely variable speed.
- Very compact dimensions.
- Compatible with series G (p. 58-59). Transport trolleys are not included.
- LiFePo4 battery technology



Loads up to			12 t	30 t
TYPE			■ JLA-E 5/12 G WITH STROKE	■ JLA-E 15/30 G WITH STROKE
Load capacity	kg		5 000	15 000
Pulling capacity	kg		12 000	30 000
Number of castors	Pieces		4	16
Castor dimensions	Ø x l	mm	140 x 59	140 x 59
Height		mm	180	200
Stroke		mm	50	50
Supporting surface of turnable	Ø C	mm	170	215
Dimensions	L1 x B1	mm	975 x 900	1 050 x 1 215
Weight with battery	kg		205	315
Speed	m/min		10	6,5
Operational time	h		4-5	4-5
Battery and charger	Pieces		1 x	1 x
Remote control, charger and belt with holder	Pieces		1 x	1 x

ORDER NO. ■ 22 005 210-G HUB ■ 22 015 210-G HUB

MOVING **POWERFUL.**

Strong. Easy. Reliable.



JUNG
HEINRICH

TRANSPORT TROLLEYS

SERIES G PROFESSIONAL

For loads up to 60 metric tons, height 180 mm

i DESCRIPTION

■ From JLB 20 up, pivoting cassettes and axles within the frame assure even pressure distribution across all castors and across the floor. No need for complex and expensive hydraulic compensation system.

■ The double castor design results in dramatically easier steering due to reduced friction forces in curves. The much lower friction resistance also causes the trolleys on the rear axis to follow in a true to track course.

■ All transport trolleys are ready for use: The steerable transport trolley is fitted with a ball bearing supported turntable and a handlebar (as shown in picture). The adjustable-width transport trolley consists of two transport units and connecting bar.

■ The load capacity specifications refer to a maximum speed of 2 km/h.

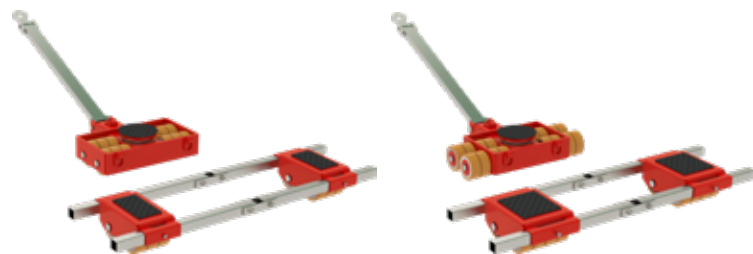

Loads up to		30 t		40 t	
TYPE		JLB 15 G	JFB 15 G	JLB 20 G	JFB 20 G
Load capacity	kg	15 000	2 x 7 500	20 000	2 x 10 000
Number of castors	Pieces	12	2 x 6	16	2 x 8
Castor dimensions	Ø x l mm	140 x 59	140 x 59	140 x 59	140 x 59
Height	mm	180	180	180	180
Supporting surface per cassette	E x F mm		220 x 120		220 x 200
Cassette dimensions	L x B x H mm		460 x 205		460 x 285
Connecting bar with joint	Length mm		2 x 1 540		2 x 1 540
Cassettes adjustable from - to	G - H mm		415 - 1 300		475 - 1 300
Supporting surface of turntable	Ø C mm	215		215	
Dimensions	L1 x B1 mm	565 x 610		565 x 741	
Handlebar with pulling eye	Length mm	1 230		1 230	
Weight JUWATHAN®plus	kg	92	63	96	80

ORDER NO. with JUWATHAN®plus ■ 09 153 140-V ■ 10 153 140-V ■ 09 203 140-V ■ 10 203 140-V



Steerable G-series trolley in action

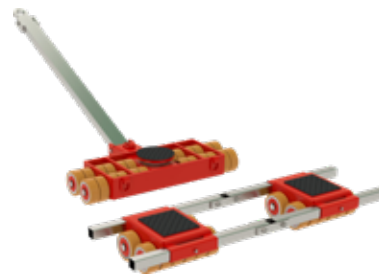

Loads up to

60 t

TYPE			JLB 30 G	JFB 30 G
Load capacity	kg		30 000	2 x 15 000
Number of castors	Pieces		24	2 x 12
Castor dimensions	Ø x l	mm	140 x 59	140 x 59
Height	mm		180	180
Supporting surface per cassette	E x F	mm		220 x 200
Cassette dimensions	L x B x 2	mm		460 x 400
Connecting bar with joint	Length	mm		2 x 1 540
Cassettes adjustable from - to	G - H	mm		530 - 1 300
Supporting surface of turnable	Ø C	mm	215	
Dimensions	L1 x B1	mm	565 x 995	
Handlebar with pulling eye	Length	mm	1 480	
Weight JUWAtan®plus	kg		140	98

ORDER NO. with JUWAtan®plus

■ 09 303 140-V

■ 10 303 140-V

TRANSPORT TROLLEYS

SERIES H PROFESSIONAL

For loads up to 200 metric tons, height 230 mm/240 mm

i DESCRIPTION

- Unrivalled: Small and light-weight trolleys at super high capacity.
- Steerable transport trolleys with pivoting cassettes for a better load distribution at all castors and the floor.
- All transport trolleys are ready for use: the steerable transport trolley is fitted with a ball bearing supported turntable and a handlebar. The adjustable-width transport trolley consists of two transport units and connecting bars.
- The double castor design results in dramatically easier steering due to reduced friction forces in curves. The much lower friction resistance also causes the castors on the rear axis to follow in a true to track course.
- The load capacity specifications refer to a maximum speed of 2 km/h.



Loads up to		80 t		120 t	
TYPE		JLB 40 H	JFB 40 H	JLB 60 H	JFB 60 H
Load capacity	kg	40 000	2 x 20 000	60 000	2 x 30 000
Number of castors	Pieces	16	2 x 8	24	2 x 12
Castors dimensions	Ø x l mm	200 x 85	200 x 85	200 x 85	200 x 85
Height	mm	230	230	230	230
Supporting surface per cassette	E x F mm		400 x 260		400 x 260
Cassette dimensions	L x B 2 mm		740 x 395		740 x 580
Connecting bar with joint	Length mm		2 x 1 540		2 x 1 540
Cassettes adjustable from - to	G - H mm		585-1 500		700-1 500
Supporting surface of turntable	Ø C mm	250		250	
Cassette dimensions	L 1 x B 1 mm	650 x 1 060		650 x 1 400	
Handlebar with pulling eye	Length mm	1 600		1 600	
Weight JUWathan®	kg	314	310	425	412
ORDER NO. with JUWathan®		■ 09 400 206-H	■ 10 400 206-H	■ 09 600 206-H	■ 10 600 206-H



Steerable H-series trolley in action

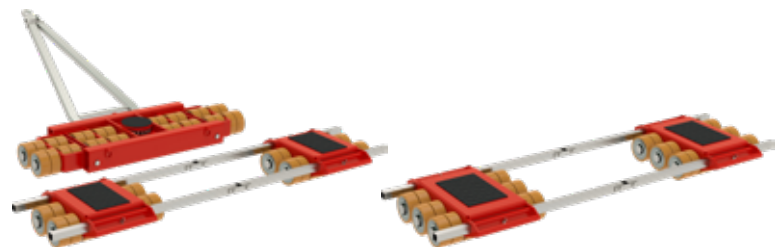

Loads up to		160 t		200 t		120 t	
TYPE		■ JL 80 H		■ JFB 80 H		■ JFB 120 H	
Load capacity	kg	80 000		2 x 40 000		2 x 60 000	
Number of castors	Pieces	32		2 x 16		2 x 24	
Castors dimensions	Ø x l mm	200 x 85		200 x 85		200 x 85	
Height	mm	240		240		240	
Supporting surface per cassette	E x F mm			400 x 260		440 x 300	
Cassette dimensions	L2 x B2 mm			750 x 830		960 x 830	
Connecting bar with joint	Length mm			2 x 3 000		2 x 3 000	
Cassettes adjustable from - to	G - H mm			830 - 2 800		830 - 2 800	
Supporting surface of turnable	Ø C mm	250					
Cassette dimensions	L1 x B1 mm	820 x 1 970					
Handlebar with pulling eye	Length mm	1 600					
Weight JUWathan®	kg	697		538		766	
ORDER NO. with JUWathan®		■ 09 800 206-H		■ 10 800 206-H		■ 10 912 206-H	

ACCESSORIES FOR FORKLIFTS

Transport dolly hitch, steering traverse & forklift clamps

i DESCRIPTION

■ **FORKLIFT HITCH** for pushing and pulling loads. Includes lashing chain to secure to forklift truck. Suitable for all JUNG trolleys outfitted with a towing eye.

■ 3 metric tons traction force.

■ Simply place on forklift forks, secure with lashing chain and go.

■ Easy maneuverability.

■ Capable of moving loads forward and in reverse.



TYPE		■ JRH 3	
Push/Pull force	kg	3 000	
Dimensions L x W x H	L x W x H mm	425 x 590 x 325	
Hitch pin	Ø mm	40	
For forks	max. mm	90 x 170	
Fork separation	min. mm	240	
Weight	kg	35	
ORDER NO.		■ 13 303 000-B	

i DESCRIPTION

■ **Forklift turntable** for maneuvering heavy loads with a forklift truck.

■ Thrust bearing supported turntable with anti-slip load pad.

■ Simply place on the forklift forks and go.

■ Reversed side equipped with anti-slip pads.

■ Usable as steerable support for 3 tons or 15 metric tons.



TYPE		■ JLT 3		■ JLT 15	
Load capacity	kg	3 000		15 000	
Dimensions	L x W x H mm	550 x 240 x 100		550 x 300 x 174	
Supporting surface of turntable	Ø mm	150		250	
For forks	max. mm	180		180	
Fork separation	min. mm	200		200	
Weight	kg	18		43	
ORDER NO.		■ 13 203 000-V		■ 13 215 000-V	

i DESCRIPTION

■ **Set of forklift clamps with tie-down straps** for binding and securing.

■ Secure valuable and unstable loads against slipping.

■ Each set includes 2 screw type fork clamps, 2 eye type fork clamps and 2 tie-down straps.

■ Simply attach the screw type fork clamps to the forks behind the load.

■ More safety for movement of top heavy loads.

■ Slide eye type fork clamps onto the tips of the forks and strap load in between for safe transport.



Secure loads with forklift clamps and tension belts

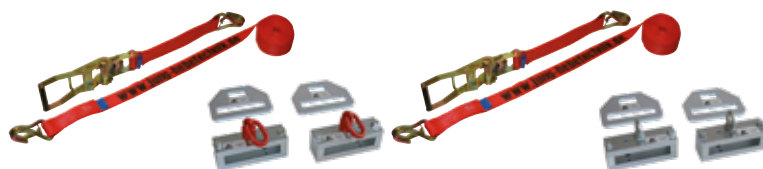
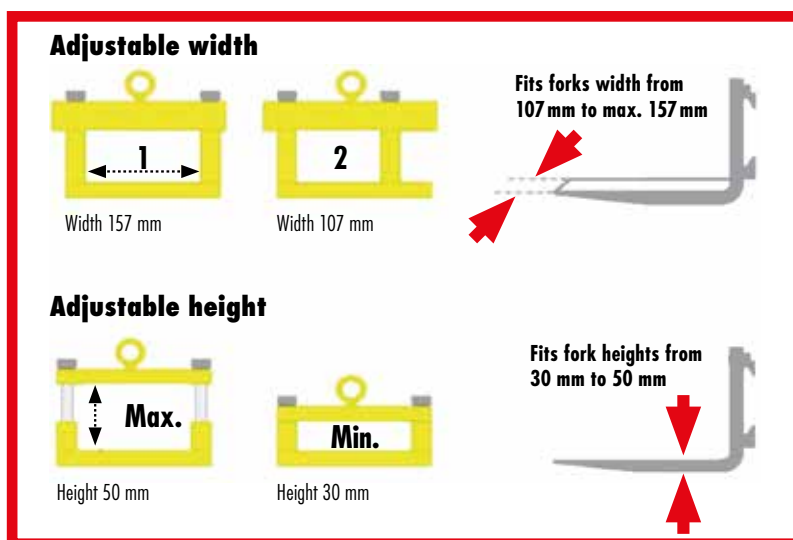

TYPE		JGK-A	JGK-R
Version		with SWIVEL eye bolts	with FIXED eye bolts
Features		turnable	fixed
Forks width	mm	107 - 157	107 - 157
Forks height	mm	30 - 50	30 - 50
Length of tie-down straps	mm	5000	5000
Bind capacity	daN	400	400
Weight	kg	19	18

ORDER NO. ■ 25 090 401-B ■ 25 090 451-B

STURDY CASTORS FOR ANY APPLICATION

High quality coatings

i DESCRIPTION

■ **JUWathan®** castor design: The coating is molded around a steel core. Two precision ball bearings are pressed into the steel core.

■ **JUWathan®plus** castor design: The basis of the **JUWathan®** castor is a further advanced coating (plus) based on **JUWathan®plus** castor. A coating of a special polyurethane-based compound is applied to an aluminium core. The thickness of the rubber has been optimised to such an extent that the rolling resistance is reduced by more than 30 %. A weight saving of almost 35 % per castor was also achieved by the new construction.

■ **JUWathan® Professional:** The professional series castor was developed based on the **JUWathan®plus** castor. The side-by-side double castor system provides higher load capacity (2x2 ball bearings) and offers greatly reduced rolling resistance. Turning of the steerable trolley requires less force because the castors can turn against one another resulting in extremely reduced friction between surface and castor. The much lower friction resistance also causes directional stability.

■ The load capacity specifications refer to a maximum speed of 2 km/h.



JUWathan® plus			■ SERIES K	■ SERIES K PROFESSIONAL	■ JKB	■ SERIES G
Load capacity		kg	750	875	375	1 250
Dimensions	D x l	mm	85 x 85	85 x 85	85 x 43	140 x 59
Inside diameter	d	mm	25	25	25	35
Weight		kg	0,8	1,05	0,5	1,85
ORDER NO.			■ 95 050 057-V	■ 95 050 089-D	■ 95 050 131-V	■ 95 050 047-V



JUWathan®			■ SERIES S	■ SERIES H
Load capacity		kg	1 000	2 500
Dimensions	D x l	mm	90 x 60	200 x 83
Inside diameter	d	mm	25	70
Weight		kg	1,2	10
ORDER NO.			■ 95 050 304-V	■ 95 050 390-D

*We grant 5 years of warranty on operability of our JUWathan®-castors except improper use or normal abrasion.

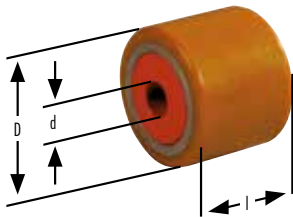

i DESCRIPTION

■ **JUWAmid**-castor design: Two precision ball bearings are pressed into a high quality polyamid coating.

■ **Steel** castor design: The steel body is made of a seamless steel tube. Two precision ball bearings are pressed into the steel core.

RECOMMENDED USE			
Recommended use for	Castor type and coat		
	JUWAtan® JUWAtan® plus JUWAtan® Professional	JUWAmid	Steel
Plain and clean floors	✓	✓	
For any floors, swarf resistant	✓		
Bad floors with roughness			✓



JUWAmid		JKB	JKB R	SERIES K
Load capacity	kg	375	375	750
Dimensions	D x l mm	85 x 43	85 x 43	85 x 85
Inside diameter	d mm	25	25	25
Weight	kg	0,35	0,35	0,85
ORDER NO.		95 050 088-P	95 050 091-P	95 050 023-P



STEEL		SERIES K	SERIES S
Load capacity	kg	750	1 000
Dimensions	D x l mm	85 x 85	90 x 60
Inside diameter	d mm	25	25
Weight	kg	2,4	2,8
ORDER NO.		95 050 043-S	95 050 305-S

USEFUL ACCESSORIES

For transport trolleys



TRANSPORT TROLLEYS SERIES K		■ STEERING ROD WITH EYE	■ TOWING BAR COMPLETE WITH REMOVABLE HANDLE	■ REMOVABLE HANDLE	■ EXTENDED CONNECTING BAR
		JLB 3 K	JLB 6 K - JL 14 K	JLB 6 K - JL 14 K	JFB 6 K - JFB 14 K
Dimensions	mm	1 120 length	1 210 length	330 x 45 x 40	2 360 length
Catalogue page		28	28-31	28-31	28-31
ORDER NO.		■ 92 010 148-B	■ 92 010 122-B	■ 92 090 300-B	■ 92 010 063-B



REVOLVING TRANSPORT TROLLEYS JKB 2 K - JKB 8 K		■ PULLING HANDLE	■ CONNECTING BAR
		JKB 2 K - JKB 8 K	JKB 2 K
Dimensions	mm	990 length	1 200 length
Catalogue page		34-36	34
ORDER NO.		■ 92 030 085-L	■ 92 030 085-V



REVOLVING TRANSPORT TROLLEYS JKB 10 G - JKB 14 G		■ PULLING HANDLE	■ CONNECTING BAR
		JKB 10 G - JKB 14 G	JKB 10 G - JKB 14 G
Dimensions	mm	1 450 length	2 000 length (on request up to 3 000 length)
Catalogue page		37	37
ORDER NO.		■ 92 226 042-B	■ 92 100 140-V



MULTI-PURPOSE TROLLEYS SERIE M		■ PULLING HANDLE	■ CONNECTING BAR
		JLF 3,5 - JLF 5	JLF 3,5 - JLF 5
Dimensions	mm	1 210 length	1 200 length
Catalogue page		38-39	38-39
ORDER NO.		■ 92 010 022-B	■ 92 030 085-V



TANDEM TROLLEYS		■ EXTENDED CONNECTING BAR		
		JTLB 6 K	JTLB 14 K	JTL 20 G & JTLB 30 G
Dimensions	mm	Length on request	Length on request	Length on request
Catalogue page		42	42	43
ORDER NO.		■ 92 010 160-B	■ 92 010 161-B	■ 92 010 163-B



ELECTRIC-POWERED TRANSPORT TROLLEYS		■ QUICK-CHARGER	■ EXTENSION BATTERY CABLE SET	■ DRIVE WHEEL		
		JLA-e 5/12 G JLA-e 15/30 G JLA-e 25/50 H	JLA-e 5/12 G JLA-e 15/30 G JLA-e 25/50 H	JLA-e 5/12 G JLA-e 15/30 G JLA-e 25/50 H	JLA-e 5/12 G JLA-e 15/30 G	JLA-e 25/50 H
Dimensions	mm	-	5 000	10 000	140 x 118 x 35	200 x 83 x 70
Catalogue page		52-53	52-53	52-53	52	53
ORDER NO.		■ 23 050 556-E ■ 93 151 003-B5 ■ 93 151 003-B10 ■ 93 050 157-V ■ 93 050 521-V				



TRANSPORT TROLLEYS SERIES G		■ EXTENDED CONNECTING BAR	
		JFB 15 G - JFB 30 G	
Dimensions	mm	3 000 length (two-piece)	
Catalogue page		58-59	
ORDER NO.		■ 92 090 060-B	



TRANSPORT BOXES		■ TOOL BOX	■ TRANSPORT BOX JLA-E		
		On request	JLA-e 5/12 G	JLA-e 15/30 G	JLA-e 25/50 H
Dimensions	mm	1 200 x 800 x 500	1 000 x 900 x 820	1 300 x 1 000 x 820	1 940 x 1 268 x 600
Catalogue page		-	52	52	53
ORDER NO.		■ 92 120 800-TK ■ 93 100 800-H ■ 93 120 800-H ■ 93 200 125-H			

TRANSPORT BOXES		■ TRANSPORT BOX JLA-E WITH STROKE	
		JLA-e 5/12 G with stroke	JLA-e 15/30 G with stroke
Dimensions	mm	1 000 x 1 100 x 810	1 300 x 1 300 x 820
Catalogue page		54	54
ORDER NO.		■ 93 101 800-H ■ 93 130 800-H	



POWER SUPPLIES		■ POWER SUPPLY	
		JLA-e 5/12 G & JLA-e 15/30 G	
Dimensions	mm	210 x 316 x 394	
Catalogue page		53	
ORDER NO.		■ 24 900 003-B	

QUICKLY
TRANSPORTED.



JUNG
●●●



HYDRO-TRANSPORTER

For loads up to 3,8 metric tons

DESCRIPTION

■ Hydro-Transporter are ideal for moving cabinets, safes, boxes or machines. They are easy and safe in use. One transporter consists of 2 transport units and two belts to connect. The transport units are attached on the sides of the load and connected with the standard belt.

■ After pumping up the movable part of the transporter on both sides the load is lifted and ready for moving.

■ Both transport units are easy to transport together.

■ Scope of delivery: 2 transport units, 2 connecting belts (5m)

■ Steering can be done by the top link bars on each unit, connected with the big wheels equipped with ball bearings. The linkage guarantees that the wheels are always in parallel direction.

■ High lifting height: 180 mm

■ The load capacity specifications refer to a maximum speed of 2 km/h.



Boxes, safes or machines - quick and easy to handle with the Hydro-Transporter!



Loads up to		1,8 t	3 t	3,8 t
TYPE		JHT 18 S	JHT 30 S	JHT 38 S
Load capacity	kg	1 800	3 000	3 800
Stroke	mm	180	180	180
Height	H mm	1 010	1 080	1 080
Length	B mm	540	585	640
Belt length	mm	5 000	5 000	5 000
Wheel diam. Ø	mm	150	200	200
Weight	kg	82	103	107

ORDER NO.

■ 30 181 002-H

■ 30 301 001-H

■ 30 351 002-H

GALVANIZED STEEL EQUIPMENT & CUSTOMISED SOLUTIONS

GALVANIZED STEEL EQUIPMENT

- Better surface protection in case of collision damage (no chipping of the topcoat).
- Improved protection against corrosion.
- Good application in sensitive environments such as clean rooms.
- Surface protection, solvent resistance.

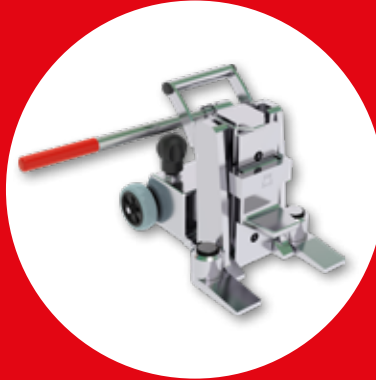

JH 6 G plus galvanized

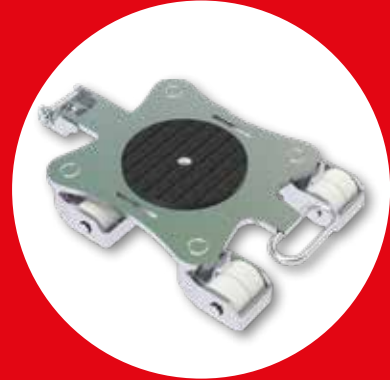

JKB 3 galvanized

CUSTOMISED SOLUTIONS



Towing devices

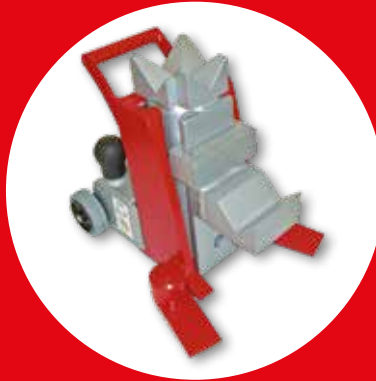

Special types of lifting toes/Special adapter for jacks



**Customised transport set
JLF & JKB**



Special Construction JLB 20 G

CATALOG OVERVIEW

Visit us on:



Tugger trains for intralogistics

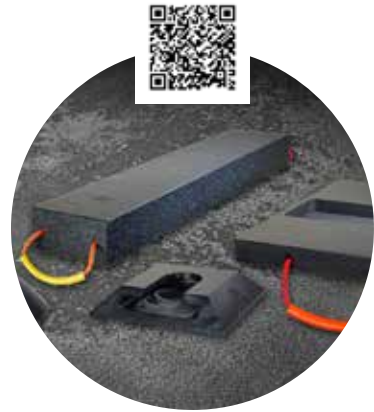

**Support technology/
Ground protection**



**Industrial hydraulics
BVA**



Leveling castors



Lifting bags

Custom solution needed?

We solve uncommon lifting and transport problems by custom solutions - safe, fast and cost effective. Please do not hesitate to contact us!

Design, manufacturing, consulting, sales and service:

JUNG Hebe- und Transporttechnik GmbH

F +49 (0)7151 30393-0
info@jung-hebetechnik.de
Biegelwiesenstraße 5-7
D-71334 Waiblingen
jung-hebetechnik.de

Unser Logo und der Name JUNG sind in der EU, in den USA und in China unter folgenden Nummern geschützt:

EU: Logo Nr. 005878897, Name Nr. 005878806

USA: Logo Reg. Nr. 3,713,850, Name Reg. Nr. 3,697,526

China: Logo Nr. 14081450A, Name Nr. 14081449A

Technische Änderungen, die der Verbesserung von Funktion und Qualität dienen, behalten wir uns vor.

Made in Germany 08.2023 · Printed in Germany

Our logo and brand name „JUNG“ are registered as trademarks in the EU, US and China with register numbers:

EU: logo no. 005878897, name no. 005878806,

USA: logo reg. no. 3,713,850, name reg. no. 3,697,526

China: logo no. 14081450A, name no. 14081449A

We reserve the right to make technical modifications which serve to improve function and quality.

Made in Germany 08.2023 · Printed in Germany

JUNG
JUNG-HEBETECHNIK.DE